



H-400/H-600 Series

Users Manual



FCC COMPLIANCE STATEMENT FOR AMERICAN USERS

This equipment has been tested and found to comply with the limits for a CLASS A digital device, pursuant to FCC 47 CFR Part 15 SUBPART B and ANSI C63.4(2003) IC ICES-003. These limits are designed to provide reasonable protection against harmful interference when the equipment is operated in a commercial environment. This equipment generates, uses, and can radiate radio frequency energy and, if not installed and used in accordance with the instructions, may cause harmful interference to radio communications. Operation of this equipment in a residential area is likely to cause harmful interference in which case the user will be required to correct the interference at his expense.

EMS AND EMI COMPLIANCE STATEMENT FOR EUROPEAN USERS

This equipment has been tested and passed with the requirements relating to electromagnetic compatibility. The equipment was also tested and passed in accordance with the European Standards for both the Radiated and Conducted emissions limits.

Technical Standard:

EMC DIRECTIVE 89/336/EEC (EN 55022 / EN 55024)

Measurement Standards:

EN 55022:1998+A1:2000+A2:2003

EN 61000-3-2:2000

EN 61000-3-3:1995+A1:2001

EN 55024:1998+A1:2001+A2:2003

IEC 61000-4-2:1995+A1:1998+A2:2000

IEC 61000-4-4:1995+A1:2000+A2:2001

IEC 61000-4-6:1996+A1:2000

IEC 61000-4-3:2002+A1:2002

IEC 61000-4-5:1995+A1:2000

IEC 61000-4-11:1994+A1:2000

CAUTION

Danger of explosion if battery is replaced incorrectly.

Only replace battery with an equivalent type as recommended by the manufacturer.

Dispose of used batteries according to the manufacturer's instructions.

Copyright and Trademark Notice

© 2008 by Tharo Systems, Inc.

It is illegal to photocopy or electronically transmit a facsimile of this manual or any portion of its contents for any means or purpose without the publisher's permission. Fines of up to \$10,000.00 may be imposed for violation.

All brand or product names are trademarks or registered trademarks of their respective companies.

TABLE OF CONTENTS

1. PRODUCT DESCRIPTION	5
General Information.....	5
Printer Options.....	6
Technical Specifications.....	7
2. GENERAL SAFETY TIPS	9
3. UNPACKING THE PRINTER AND ACCESSORIES	9
4. IDENTIFYING COMPONENTS	10
5. PRINTER SETUP	13
USB Installation.....	14
6. CONTROL PANEL	15
General Description and Operation.....	15
Setting Mode.....	16
Menu items and available options in Setting Mode.....	17
Diagram of the Setting Mode Menu.....	20
7. LOADING MEDIA	21
Ribbon Installation.....	21
Label Installation.....	22
Activating the Stripper Sensor.....	24
8. INSTALLING THE PRINTER'S OPTIONAL ACCESSORIES	25
H-400 Internal Rewind Module.....	25
H-400 Series Strip-and-Peel Setup.....	27
H-600 Series Stripper Module Installation.....	29
Rewind Bracket Installation and Use.....	32
Cutter Installation.....	33
9. USING THE PRINTER WITH A PS/2 KEYBOARD	35
Entering/Exiting Keyboard Mode.....	35
Menu Items and Options available in Keyboard Mode.....	36
Downloading to the Flash Memory using EASYLABEL.....	37
APPENDIX A. COMMUNICATION INTERFACES	38

Parallel Interface.....	38
Serial Interface.....	38
USB Interface.....	39
PS/2 Interface.....	39
Optional Applicator Interface.....	39
APPENDIX B. ERROR MESSAGES / TROUBLESHOOTING.....	40
Self-Test.....	40
Dump Mode.....	40
LCD Error Messages and Descriptions.....	41
Problems and Recommended Solutions	42
APPENDIX C. MAINTENANCE AND ADJUSTMENT	43
Thermal Printhead Cleaning.....	43
Printhead Module Installation / Removal Instructions.....	44
Printhead Print Line Adjustment.....	45
Thermal Printhead Balance Adjustment.....	46
Ribbon Tension Adjustment	46
Ribbon Shield Adjustment.....	47
Auto Sensing	48
Upgrading the Printer's Firmware.....	48
Downloading True Type Fonts to the Printer's Flash Memory	49
Clearing Cutter Jams on the H-400 Series Cutter.....	51
Cleaning Adhesive from the H-400 Series Cutter Blade.....	51

Warranty Information

The THARO H-400/H-600 Printers are warranted against defects in material or workmanship for 12 months (365 days) from the date of original shipment by THARO SYSTEMS, INCORPORATED. This warranty does not cover normal wear and tear and shall be null and void if the equipment is modified, improperly installed or used, damaged by accident or neglect, or in the event any parts are improperly installed or replaced by the user.

Since Printhead wear is part of normal operations, a Printhead warranty of 3 months (90 days) from the date of original shipment by THARO SYSTEMS, or 25,000 linear meters of use, whichever comes first. To qualify for this warranty, the Printhead must be returned to THARO or another authorized service center. Although the user is not required to purchase THARO brand supplies (media and/or ribbons), to the extent it is determined that the use of other supplies (media and/or ribbons) shall have caused any defect in the thermal Printhead for which a warranty claim is made, the user shall be responsible for THARO's customary charges for labor and materials to repair such defect. To the extent that it is determined that failure to follow the preventive maintenance schedule and procedures listed in the User Manual shall have caused any defect in the thermal Printhead for which a warranty claim is made, this limited warranty shall be void. Any Printhead returned to THARO with scratches or abrasions on the Printhead at the point of failure will be deemed abused and no warranty replacement will be provided.

THARO SYSTEMS' SOLE OBLIGATION UNDER THIS WARRANTY SHALL BE TO FURNISH PARTS AND LABOR FOR THE REPAIR OR REPLACEMENT OF PRODUCTS FOUND TO BE DEFECTIVE IN MATERIAL OR WORKMANSHIP DURING THE WARRANTY PERIOD.

As a condition of this warranty, the user must: (a) obtain a THARO Return Authorization for the Printer, or subassembly(s); (b) ship the Printer or subassembly(s), transportation prepaid to the authorized service location; and (c) include with the Product or subassembly(s) a written description of the claimed defect. Unless THARO SYSTEMS authorizes return of the entire Product, the user shall return only the subassembly(s). Products returned shall be packaged in the original packing and shipping container or comparable container. In the event equipment is not so packaged or if shipping damage is evident, it will not be accepted for service under warranty. Surface transportation charges for the return of the Printer to the customer shall be paid by THARO SYSTEMS within the 48 contiguous states and the District of Columbia. Customer shall pay shipping costs, customs clearance, and other related charges outside the designated area. If THARO SYSTEMS determines that the Product returned to it for warranty service or replacement is not defective as herein defined, BUYER shall be subject to a minimal labor charge and all costs of handling and transportation.

Warranty Exclusions and Conditions

The above warranties are in lieu of all other warranties, expressed or implied, oral or written, statutory or otherwise, including any **implied warranty of merchant-ability or fitness for a particular purpose**.

THARO SYSTEMS shall not be responsible for the specific application to which any Products are applied, including but not limited to compatibility with other equipment.

All statements, technical information and recommendations relating to THARO Products are based upon tests believed to be reliable but do not constitute a guarantee or warranty.

THARO SYSTEMS SHALL NOT, UNDER ANY CIRCUMSTANCES WHATSOEVER, BE LIABLE TO BUYER OR ANY OTHER PARTY FOR LOST PROFITS, DIMINUTION OF GOODWILL OR ANY OTHER SPECIAL OR CONSEQUENTIAL DAMAGES WHATSOEVER WITH RESPECT TO ANY CLAIM HEREUNDER. IN ADDITION, THARO SYSTEMS' LIABILITY FOR WARRANTY CLAIMS SHALL NOT, IN ANY EVENT, EXCEED THE INVOICE PRICE OF THE PRODUCT CLAIMED DEFECTIVE, NOR SHALL THARO SYSTEMS BE LIABLE FOR DELAYS IN REPLACEMENT OR REPAIR OF PRODUCTS.

No salesperson, representative or agent of THARO SYSTEMS is authorized to make any guarantee, warranty, or representation in addition to the foregoing warranty.

NO WAIVER, ALTERATION, ADDITION, OR MODIFICATION OF THE FOREGOING WARRANTIES SHALL BE VALID UNLESS MADE IN WRITING AND SIGNED BY AN EXECUTIVE OFFICER OF THARO SYSTEMS.

1. Product Description

General Information

The THARO H-400 Series and H-600 Series Printers are heavy duty, high performance, thermal transfer/direct thermal label Printers, suitable for large volume printing requirements in industrial applications. With robust metal outer casing and inner mechanism, the Printers are designed to be durable, tough and reliable, even in the harshest environments.

The THARO H-427 features a Printhead density of 8 dots/mm (203 dots/in) and a maximum print length of 4572mm (180"). The THARO H-436 features a Printhead density of 12 dots/mm (300 dots/in) and a maximum print length of 2159mm (85").

The H-400 Series Printers provide high-speed performance of up to 7 inches per second with an 8" outside diameter label roll and 450 meter length ribbon capacities for large volume throughput. The THARO H-427 and H-436 feature a large, backlit LCD that is easy to read and is capable of displaying either text or graphics, making operation easy. A Real-Time Clock for time and date stamping of labels is standard on the H-427 and H-436. Also standard on the THARO H-427 and H-436 Printers is a Stripper Sensor to sense the presence of printed labels. With the Stripper Sensor activated, application software such as Tharo's EASYLABEL[®] can operate the Printers in Peel-Off mode.

The THARO H-626 features a Printhead density of 8 dots/mm (203 dots/in) and a maximum print length of 2997.2mm (118"). The THARO H-634 features a Printhead density of 12 dots/mm (300 dots/in) and a maximum print length of 1371.6mm (54").

The H-600 Series Printers provide high-speed performance of up to 6 inches per second with an 8" outside diameter label roll and 450 meter length ribbon capacities for large volume throughput. The THARO H-626 and H-634 feature a large, backlit LCD that is easy to read and is capable of displaying either text or graphics, making operation easy. A Real-Time Clock for time and date stamping of labels is standard on the H-626 and H-634.

All THARO H-400 Series and H-600 Series Printers support the use of internal Flash or the use of CompactFlash memory cards for storing downloaded label formats, graphics, and fonts. Using this memory the Printers can be operated **without** being connected to a computer, which represents a great advantage regarding their flexibility.

Printer Options

Internal Rewind (H-400 Series)

The Internal Rewind can be used with the Stripper Sensor to rewind the label liner when the Printer is operating in strip-and-peel mode. It can also be used to wind a partial roll of labels as they are printed.

Internal Rewind and Stripper Sensor (H-600 Series)

The Internal Rewind and Stripper Sensor can be used to rewind the label liner when the Printer is operating in strip-and-peel mode. It can also be used to wind a partial roll of labels as they are printed.

Cutter (H-400 Series)

The optional Cutter can be used to cut labels or tag stock. Cutter options include a choice of: cut after each label, cut after a specific quantity of labels or cut at the end of a print job.

Heavy Duty Cutter (H-600 Series)

The optional Cutter can be used to cut labels, tag stock or foil. Cutter options include a choice of: cut after each label, cut after a specific quantity of labels or cut at the end of a print job.

External Keyboard

The PS/2 Keyboard connector allows you to connect your Printer to any standard PS/2 Keyboard. This will allow you to input variable data to a label format stored in Flash memory or on the CompactFlash memory card.

Ethernet Adapter

The Internal Ethernet Adapter Card provides networking capability to the H-400 Series and H-600 Series Printers.

Applicator Interface

The applicator interface provides a means of communications between an applicator and the H-400 Series and H-600 Series Printers.

EASYLABEL® - Label Design Software for Windows

EASYLABEL® labeling software allows you to drive your Printer and create a full range of label formats with a minimum of effort. EASYLABEL can be installed under Microsoft Windows® on IBM PCs and compatibles. For further information about EASYLABEL, please contact your THARO Reseller.

PA500w Applicator

The compact PA500w is fast and simple to operate. You can quickly setup and changeover the PA500w for top apply or side apply. The PA500w also integrates easily into existing production lines and packaging systems.

PA1200 Applicator

The PA1200 is available in front apply, dual tamp and corner wrap configurations. The PA1200 requires only minimal adjustments for applying labels to either the top or side of the product making it easy to use.

PA2000 Applicator

The PA2000 is quick and accurate, applying up to 58 labels per minute, depending on label size, printer used, and height of the products. The PA2000 has a small footprint and is available in Tamp or Tamp/Blow configurations. The PA2000 features a remote front panel for easy access regardless of the Printer orientation. A Specialty Tamp Option is also available for very small, delicate, high precision print and apply applications.

Technical Specifications - Specifications are subject to change without notice.

MODEL	H - 427	H - 436
Resolution	203 dpi (8 dot/mm)	300 dpi (12 dot/mm)
Print Mode	Thermal Transfer / Direct Thermal	
CPU	32 Bit	
Memory	4MB Flash, 16MB SDRAM	
Print Speed	50.8mm (2") ~ 177.8mm (7")/sec	50.8mm (2") ~ 152.4mm (6")/sec
Print Length	5mm (0.20") ~ 4572mm (180")	5mm (0.20") ~ 2159mm (85")
Print Width	13mm (0.51") ~ 104mm (4.09")	13mm (0.51") ~ 105.7mm (4.16")
Sensor Type	Moveable transmissive sensor and reflective sensor; left aligned	
Sensor Detection	Type: Label gap and black mark sensing Detection: Label length auto sensing and/or program command setting	
Media	Label Roll: Max. 203mm (8.0") Core Diameter: 38.1mm (1.5") ~ 76.2mm (3") Width: 25.4mm (1") ~ 118.00mm (4.64") Thickness: 0.06mm (0.002") ~ 0.25mm (0.009")	
Ribbon	Length: 450m (1471') Type: Ink inside or ink outside thermal transfer ribbons (wax, resin and wax/resin) in widths of 30 to 110mm (1.18" to 4.33"). Core inner diameter 25.4mm (1"). Maximum ribbon roll diameter 76mm (2.99").	
Printer Language	TPL (Tharo Programming Language)	
Software	EASYLABEL ® Start Microsoft Windows Drivers, CUPS (Common UNIX Printing System) Driver	
Resident Fonts	11 resident alphanumeric fonts (including OCR A & B), are expandable eight times horizontally and vertically. Scalable Font (Code Page 850 & 852)	
Downloadable Fonts	Windows Bit-map fonts, TrueType fonts and Asian fonts	
Image Handling	BMP and PCX	
Bar Codes	Code 39, Code 93, Code 128 (subsets A, B, C), UCC/EAN-128, UPC-A, UPC-E, UPC and EAN 2 or 5 digit extensions, I 2 of 5, EAN-8, EAN-13, Codabar, Postnet, DUN 14, MaxiCode, Plessey, Telepen, FIM, China Postal Code, RPS 128, PDF417, Data Matrix & QR Code	
Interfaces	RS-232 Serial (Baud rate 4800 ~ 115200, XON/XOFF, DSR/DTR) USB (2.0) CompactFlash card slot Parallel PS/2 Keyboard Port	
Control Panel	Backlit LCD Display: 128 dot x 64 dot Graphical LCD Three single-color LEDs: Power, Ready, Error Three Control Keys: Feed, Pause, Cancel	
Power	Auto Switching 110/240VAC, 50/60 Hz	
Real Time Clock	Standard	
Environment	Operation: 32° F to 104° F (0° C to 40° C) Storage: -40° F to 122° F (-20° C to 50° C)	
Humidity	Operation: 30-85%, non-condensing. Free air. Storage: 10-90%, non-condensing. Free air.	
Printer Dimensions	Length: 512mm (20.15") Height: 291mm (11.45") Width: 274mm (10.78") Weight: about 15Kg (33.1 lbs)	
Options	Cutter Internal Rewind Ethernet Adapter Applicator Interface PA2000, PA1200 or PA500w Applicator EASYLABEL Silver, Gold, Platinum or Multi-User	

MODEL	H - 626	H - 634
Resolution	203 dpi (8 dot/mm)	300 dpi (12 dot/mm)
Print Mode	Thermal Transfer / Direct Thermal	
CPU	32 Bit	
Memory	4MB Flash, 16MB SDRAM	
Print Speed	50.8mm (2") ~ 152.4mm (6")/sec	50.8mm (2") ~ 101.6mm (4")/sec
Print Length	13mm (0.51") ~ 2997.2mm (118")	13mm (0.51") ~ 1371.6mm (54")
Print Width	50.8mm (2") ~ 168mm (6.61")	
Sensor Type	Moveable transmissive sensor and reflective sensor; left aligned	
Sensor Detection	Type: Label gap and black mark sensing. Detection: Label length auto sensing and/or program command setting	
Media	Label Roll: Max. 203mm (8.0") Core Diameter: 38.1mm (1.5") ~ 76.2mm (3") Width: 50.8mm (2") ~ 178.00mm (7") Thickness: 0.06mm (0.002") ~ 0.25mm (0.009")	
Ribbon	Length: 450m (1471') Type: Ink inside or ink outside thermal transfer ribbons (wax, resin and wax/resin) in widths of 60 to 174mm (2.36" to 6.85"). Core inner diameter 25.4mm (1"). Maximum ribbon roll diameter 76mm (2.99").	
Printer Language	TPL (Tharo Programming Language)	
Software	EASYLABEL ® Start Microsoft Windows Drivers, CUPS (Common UNIX Printing System) Driver	
Resident Fonts	11 resident alphanumeric fonts (including OCR A & B), are expandable eight times horizontally and vertically. Scalable Font (Code Page 850 & 852)	
Downloadable Fonts	Windows Bit-map fonts, TrueType fonts and Asian fonts	
Image Handling	BMP and PCX	
Bar Codes	Code 39, Code 93, Code 128 (subsets A, B, C), UCC/EAN-128, UPC-A, UPC-E, UPC and EAN 2 or 5 digit extensions, I 2 of 5, EAN-8, EAN-13, Codabar, Postnet, DUN 14, MaxiCode, Plessey, Telepen, FIM, China Postal Code, RPS 128, PDF417, Data Matrix & QR Code	
Interfaces	RS-232 Serial (Baud rate 4800 ~ 115200, XON/XOFF, DSR/DTR) USB(2.0) CompactFlash card slot Parallel PS/2 Keyboard Port	
Control Panel	Backlit LCD Display: 128 dot x 64 dot Graphical LCD Three single-color LEDs: Power, Ready, Error Three Control Keys: Feed, Pause, Cancel	
Power	Auto Switching 110/240VAC, 50/60 Hz	
Real Time Clock	Standard	
Environment	Operation: 32° F to 104° F (0° C to 40° C) Storage: -40° F to 122° F (-20° C to 50° C)	
Humidity	Operation: 30-85%, non-condensing. Free air. Storage: 10-90%, non-condensing. Free air.	
Printer Dimensions	Length: 516mm (20.31") Height: 285mm (11.22") Width: 345mm (13.58") Weight: about 16.6Kg (36.6 lbs)	
Options	Heavy-Duty Cutter Internal Rewind Stripper Sensor (requires Internal Rewind) Ethernet Adapter Applicator Interface PA2000 Applicator EASYLABEL Silver, Gold, Platinum or Multi-User	

2. General Safety Tips



CAUTION!

- During the print process the Printhead will become hot. Do NOT attempt to clean the Printhead until it has had time to cool.
- The Printhead is the Most Fragile part of your Printer. Do NOT use sharp or hard objects to clean the Printhead. Do NOT touch the glass surface of the Printhead with your hand.
- This Printer is built exclusively to print labels, tickets and tags, continuous paper, etc. Only use media that is recommended for a direct thermal or thermal transfer Printer.
- The Printer is configured for input voltages of 110 to 240 V. Connect only to a power outlet with a grounded contact. Always ensure the Printer is switched OFF before connecting the power cord to an electrical outlet.
- Do not expose the Printer to moisture or operate it in wet or damp areas.
- The Printer will operate with the cover open if necessary. This is not recommended, as the Printer's moving or rotating parts can cause injury. Keep long hair, jewelry and loose clothing away from any moving parts.
- Remove the power cord from the rear of the Printer when disconnecting or attaching accessories such as rewind units, cutters, etc.

3. Unpacking the Printer and Accessories

Check the condition of the packaging and contents for possible damage during transit.



NOTICE: Please retain original boxes and all original packing materials in case the Printer must be returned.

In addition to this manual the following items should be included:

- Bar Code Printer
- Power Cord (110V or 230V)
- Empty Ribbon Roll
- Quick Start Guide
- Accessories CD: Includes Label Software, Manuals, Windows Drivers and CUPS Driver.

The following additional items are necessary for generating labels from your Printer:

- Serial, Parallel, or USB cable
- Applicable media (label stock/ribbon)

4. Identifying Components



1.	Control panel
2.	Bottom Front Cover
3.	Media Window
4.	Top Cover

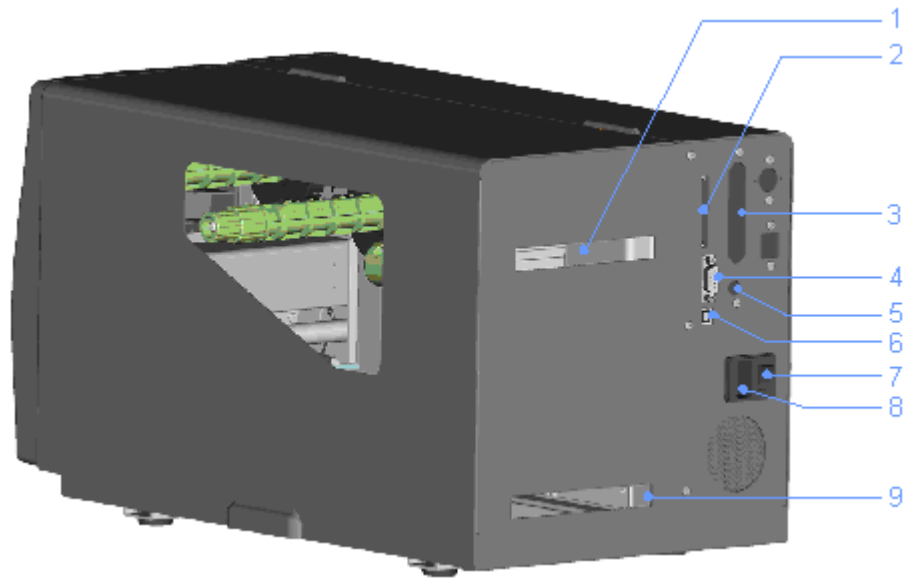

1.	Fan-Fold Label Slot
2.	CF Card Slot
3.	Parallel Port
4.	Serial Port
5.	PS/2 Port
6.	USB Port
7.	Power Switch
8.	Power Socket
9.	Fan-Fold Label Slot

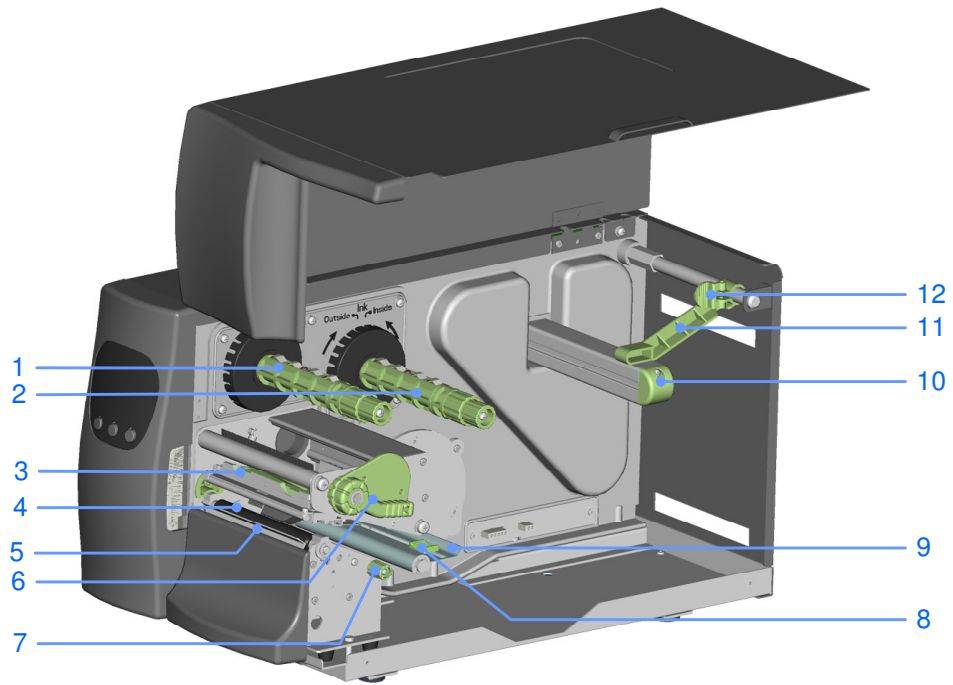

1.	Ribbon Rewind Shaft
2.	Ribbon Supply Shaft
3.	Printer Mechanism
4.	Platen
5.	Tear off Bar
6.	Printhead Lever
7.	Sensor Knob
8.	Label Guide
9.	Label Tension Plate
10.	Label Roll Bar
11.	Label Supply Guide
12.	Label Alignment Guide

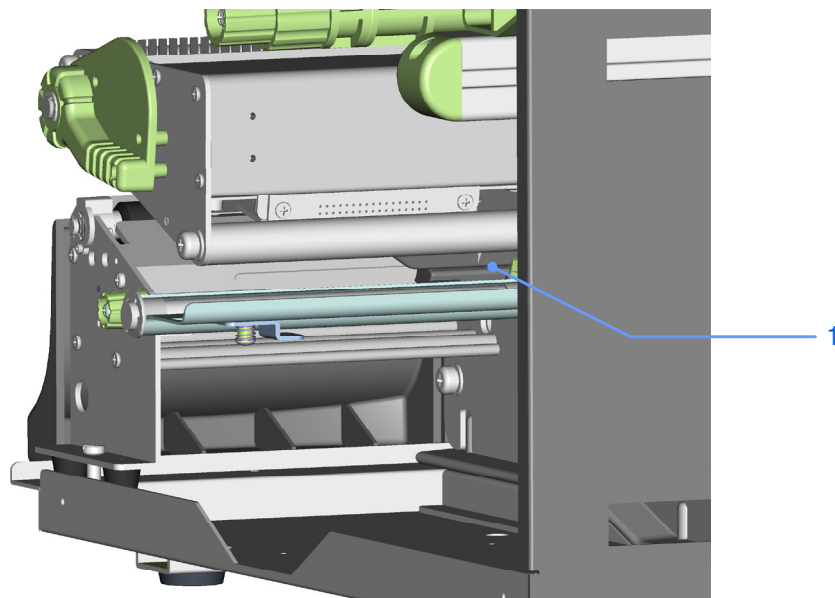

1.	Movable sensor
----	----------------

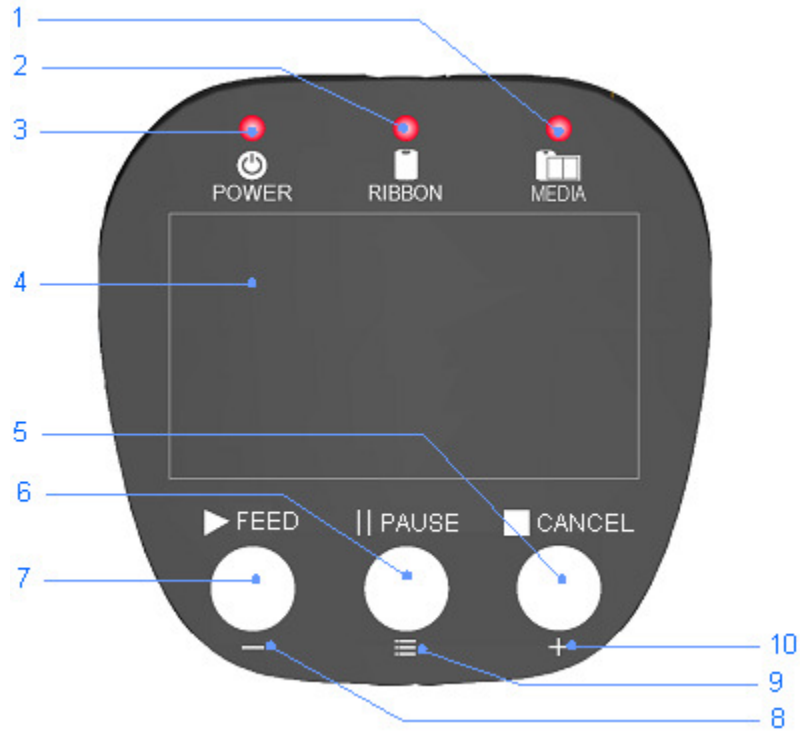

1.	MEDIA LED
2.	RIBBON LED
3.	POWER LED
4.	LCD
5.	CANCEL Key
6.	PAUSE Key
7.	FEED Key
8.	MINUS (-) Key (Setting Mode)
9.	MENU Key (Setting Mode)
10.	PLUS (+) Key (Setting Mode)

5. Printer Setup



CAUTION!

When choosing a location for the Printer, ensure that the Printer and operator remain dry. If the Printer or the operator get wet, serious injury to the operator or damage to the Printer may occur.



CAUTION!

Make sure that the Printer's power switch is in the "O" or "Off" position before proceeding with the installation.

1. Plug the supplied power cord into the Printer's power socket.
2. Plug the other end of the power cord into a grounded outlet.
3. Select the correct cable for the chosen interface. The Printer can be directly connected to the PC in one of 3 ways: USB, parallel, or serial. For the connection to the USB port use a suitable USB cable. For the connection to the PC's parallel port use a suitable parallel interface cable. If the serial interface is used make sure the proper serial cable is used. You can find pin assignments and descriptions for all three interfaces connectors in Appendix A.



NOTICE!

For Serial communications make sure that the "COM Port Setup Options" in the Printer's front panel are configured the same as the software you will be using with the Printer.

4. Connect the Printer to the computer with the selected cable. Then secure the cable using any screws or clips attached to the connectors. These prevent the connection from working loose.
5. Turn the Printer on, the LCD will show the Printer model and firmware version.

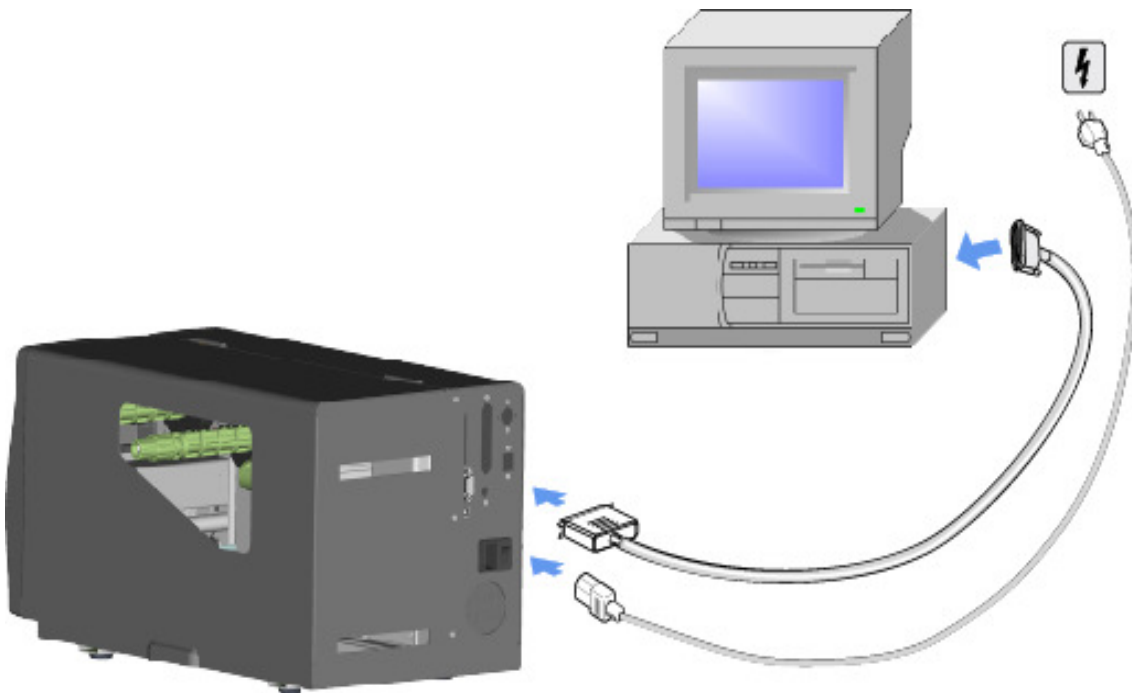

USB Installation

1. USB is a Plug & Play facility. Once the USB cable is connected from PC to the printer, the PC will automatically detect the new device and begin the installation process.

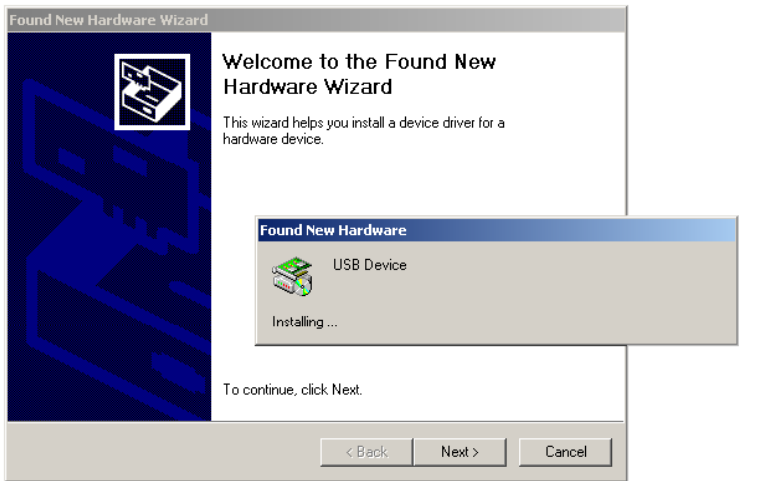

2. Select 'Specify a location' and specify the path of the printer driver.
3. Follow the instructions in the Wizard to complete the installation.

Note: These instructions are only for use when using Windows Drivers. When using label software such as EASYLABEL® you can disable the prompting for Windows Drivers. Consult the knowledgebase on our website at www.tharo.com for detailed instructions.

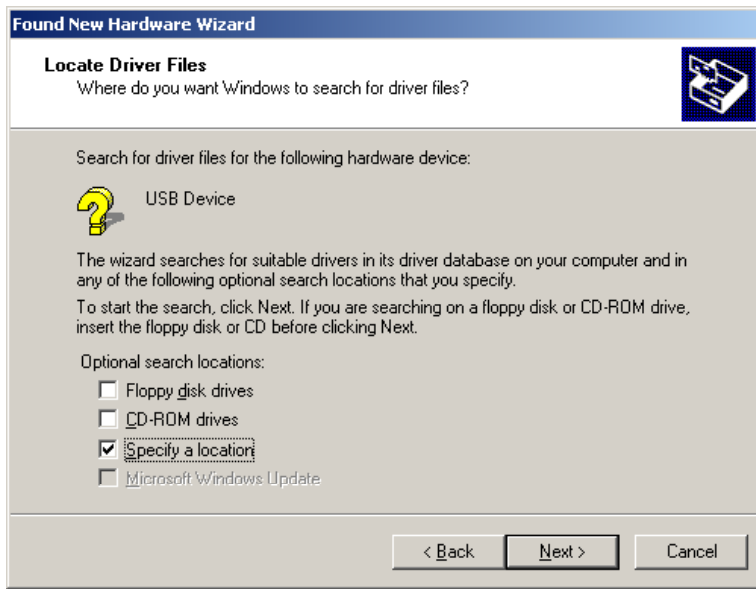

6. Control Panel

General Description and Operation

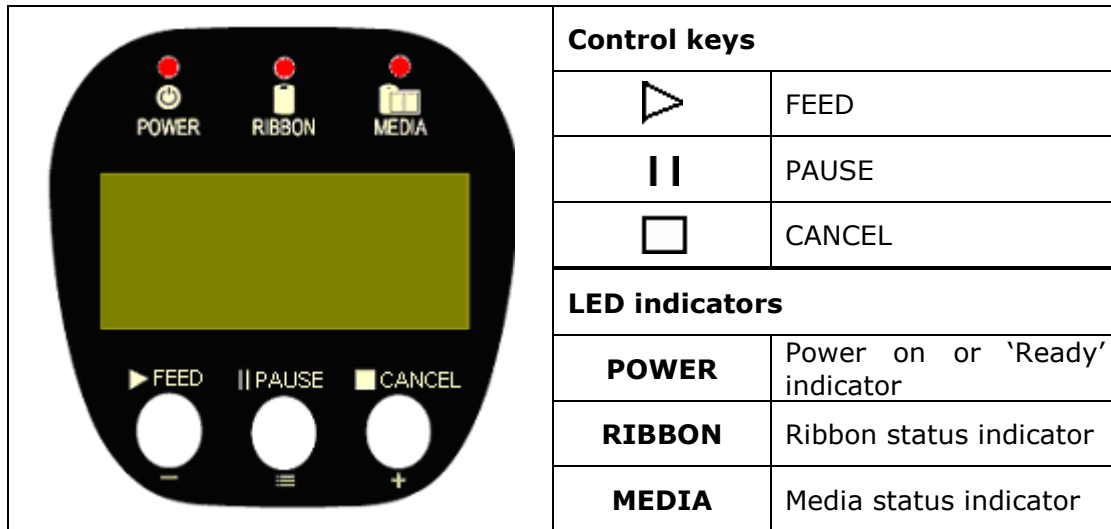

FEED Key

After pressing the FEED Key, the printer will feed the media (according to media type) to the specified stop position. When printing with continuous media, pressing the FEED Key will feed media out to a certain length. When printing labels with gaps, pressing the FEED Key will feed one label at a time; if the label is not fed out to the correct position, please proceed with the Auto Sensing.

|| PAUSE Key







When pressing the PAUSE Key in standby mode, the printer will go into the Pause Mode, and the Display will indicate "<Printer Model> Pause." In this mode, the printer will not be able to receive any commands. Pressing the PAUSE Key again, will switch the printer back to standby.

Pressing the PAUSE Key while printing, will pause the print job. When the PAUSE Key is pressed again, the printer will resume printing, for example, if the print job contains 10 labels, and the PAUSE Key is pressed after 2 labels are printed to pause printing; when pressing the PAUSE Key again, the printer will finish printing the remaining 8 labels.

CANCEL Key

When pressing the CANCEL Key while printing, the LCD Display will show "xxxxxxx Cancel," this means the printer has cancelled the current print job. For example, if the print job contains 10 labels and the CANCEL Key is pressed after 2 labels are printed, the remaining 8 labels will not be printed, and the printer will return to standby.

Using combinations of FEED, PAUSE, and CANCEL Keys, the printer can perform various functions as follows:

Item	Key	Beep	LCD Message	Description
Self Test	 + Power on	3 beeps	Wait for Self-Test	Press and hold the FEED Key while turning on the printer until the printer beeps 3 times. The printer will perform a Self Test.
Dump Mode	 + Power on	4 beeps	Dump Mode	Press and hold the FEED Key while turning on the printer until the printer beeps 4 times. The printer will enter Dump Mode.
Auto Sensing	 + Power on	3 beeps	Auto Sensing	Press and hold the PAUSE Key while turning on the printer until the printer beeps 3 times. The printer will perform an Auto Sensing.
Go to Default	 +  + Power on	2 beeps twice	Go to Default	Press and hold the FEED and the CANCEL Keys while turning on the printer until the printer beeps 2 times. The printer settings will go to factory defaults.
Setting Mode		3 beeps	Setting Mode	Press and hold the PAUSE Key about 3 to 4 seconds until the printer beeps 3 times. The Printer will enter Setting Mode.

Setting Mode

In Setting Mode you are able to change the various settings that control the operation of the Printer such as: printing mode, options, media type, interface options, and language display.

1. To enter Setting Mode: Press and hold the PAUSE Key for about 3 to 4 seconds until the printer beeps 3 times. The LCD will flash "Setting Mode".
2. You are now in "Setting Mode". The first Menu Item will be displayed on the LCD.

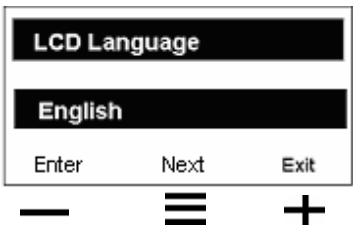
	<p>After entering the Setting mode, the first highlight on the Display indicates the current selected Menu Item.</p> <ul style="list-style-type: none"> ➤ Press the FEED/ENTER Key to change this Menu Item. ➤ Press the PAUSE/NEXT Key to move to the next Menu Item. ➤ Press CANCEL/EXIT to leave Setting Mode.
---	--

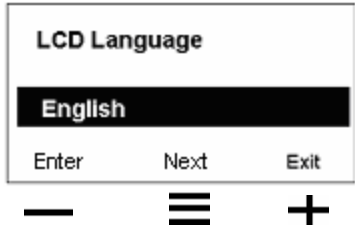
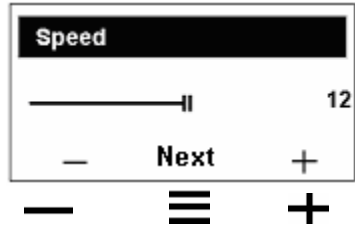
	<p>For Menu Items that are a list of selectable options, the first line indicates the current item and the second line indicates current setting.</p> <ul style="list-style-type: none"> ➤ Press the FEED/ENTER Key to select the displayed value for this Menu Item. ➤ Press the PAUSE/NEXT Key to move to the next available selection for this Menu Item. ➤ Press CANCEL/EXIT to go back to the Setting Mode Menu.
	<p>For Menu Items that are adjustment settings, the first line indicates the current item and the second line indicates current value.</p> <ul style="list-style-type: none"> ➤ Press the + /CANCEL Key to increase the value. ➤ Press the — /FEED Key to decrease the value. ➤ Press the ≡ /PAUSE Key to go to next Menu Item.

3. Before exiting Setting Mode, the Printer will prompt the user if the settings should be saved or not.
4. After user's response, on whether or not to save the settings, the Printer will return to Standby Mode.

Menu items and available options in Setting Mode



NOTICE!

"Default Setting" is the value of the setting as delivered from the factory. Any changes made in Setup Mode are saved after the Printer is turned off.

Darkness	Default: 2 Sets the print darkness. Range is 0 to 19.
Speed	Sets the print speed. Range varies based on the printer.
Adjust Stop Position	Default: 4 Adjusts the final stop position and is used to help make up for mechanical differences between two printers. This value is added to the value sent with the ^Ex command to adjust the stop position of printing. The range is from 0 to 10.
Printhead Position	Default: 0 Defines the location of the print image on the label. Range is -100 to +100 (hundredths of inches) (-.254mm - .254mm). Positive values cause the print image to be moved to the trailing edge of the label.
Printing Mode	Default: Thermal Transfer Thermal Transfer: When printing, a ribbon must be installed to transfer the image onto the media. Direct Thermal: When printing, no ribbon is necessary; requires direct thermal media.

Option Setup	<p>Default: Option OFF Strip Mode: turns the Stripper Sensor on. Cutter Mode: turns the Cutter on. Applicator: Sets printer to be used with an applicator or foot switch. None: no options are attached.</p>
Sensor Setup	<p>Default: Gap paper Gap: for labels with liner and gap, or hang tags. Black Mark: for label or plain paper with black mark on the back. Continuous: continuous media without gaps or sensing marks.</p>
COM Port Setup	<p>Baud Rate: Default: 9600 bits 4800 bits 9600 bits 19200 bits 38400 bits 57600 bits 115200 bits</p>
	<p>Parity: Default: None None Parity Odd Parity Even Parity</p>
	<p>Data Bits: Default: 8 bits 7 bits 8 bits</p>
	<p>Stop Bits: Default: 1 bit 1 bit 2 bits</p>
Auto Sensor	<p>Default: Auto mode Auto Mode: automatically senses and sets the label type (black mark, gap or plain paper) and length. Gap Mode: detects label stock with gaps. Black Mark Mode: detects label stock with black marks.</p>
LCD Language	<p>Default: English English Simplified Chinese Traditional Chinese Spanish Italian Dutch French Turkish German</p>
Code Page Setup	<p>Default: Code Page 850 Code Page 850 Code Page 852</p>
Keyboard Setup	<p>Default: US US UK French German Spanish Italian Finnish Dutch Belgian</p>
Keyboard Mode	<p>Pressing the FEED Key allows the user to use a keyboard connected to the Printer for stand-alone printing. (This is the same as connecting the keyboard to the Printer and then pressing the 'Y' key.)</p>

Buzzer Setup	<p>Default: ON ON: The printer will sound the buzzer (beep) as a confirmation of most events. OFF: The printer will only sound the buzzer (beep) when there is a condition that requires the operator's attention.</p>
Smart BackFeed	<p>Default: OFF When in stripper, applicator, or cutter mode, a label is printed and moved forward to be peeled off, taken by applicator or cut. If Smart Backfeed is ON, the next label will be partially printed so the printer does not have to backfeed to find the original starting point when printing continues. ON: Turns smart backfeed on. OFF: Turns smart backfeed off.</p>
Password	<p>Default: OFF ON: Allows user to set a password to restrict setup changes. The Printer will prompt for a password message before entering Setting Mode when password protection is enabled. OFF: Allows any user to change setup selections.</p>
Top Of Form	<p>Default: ON Enables or disables the top of form feature in the printer. This feature tells the printer to either feed a blank label (ON) or immediately start to print without first feeding a blank label (OFF) upon power up or after opening and closing the Printhead. ON: Printer will feed a blank label. OFF: Printer will immediately start to print without first feeding a blank label.</p>
Ethernet	<p>'Go to Default' is the only option. <i>(Other options may be added in the future.)</i> Pressing the FEED Key will reset the optional Ethernet Module to factory default settings.</p>
Preview	<p>Press Enter to select the Preview option. Press the Next Key to scroll through the list of configuration options.</p>

Diagram of the Setting Mode Menu

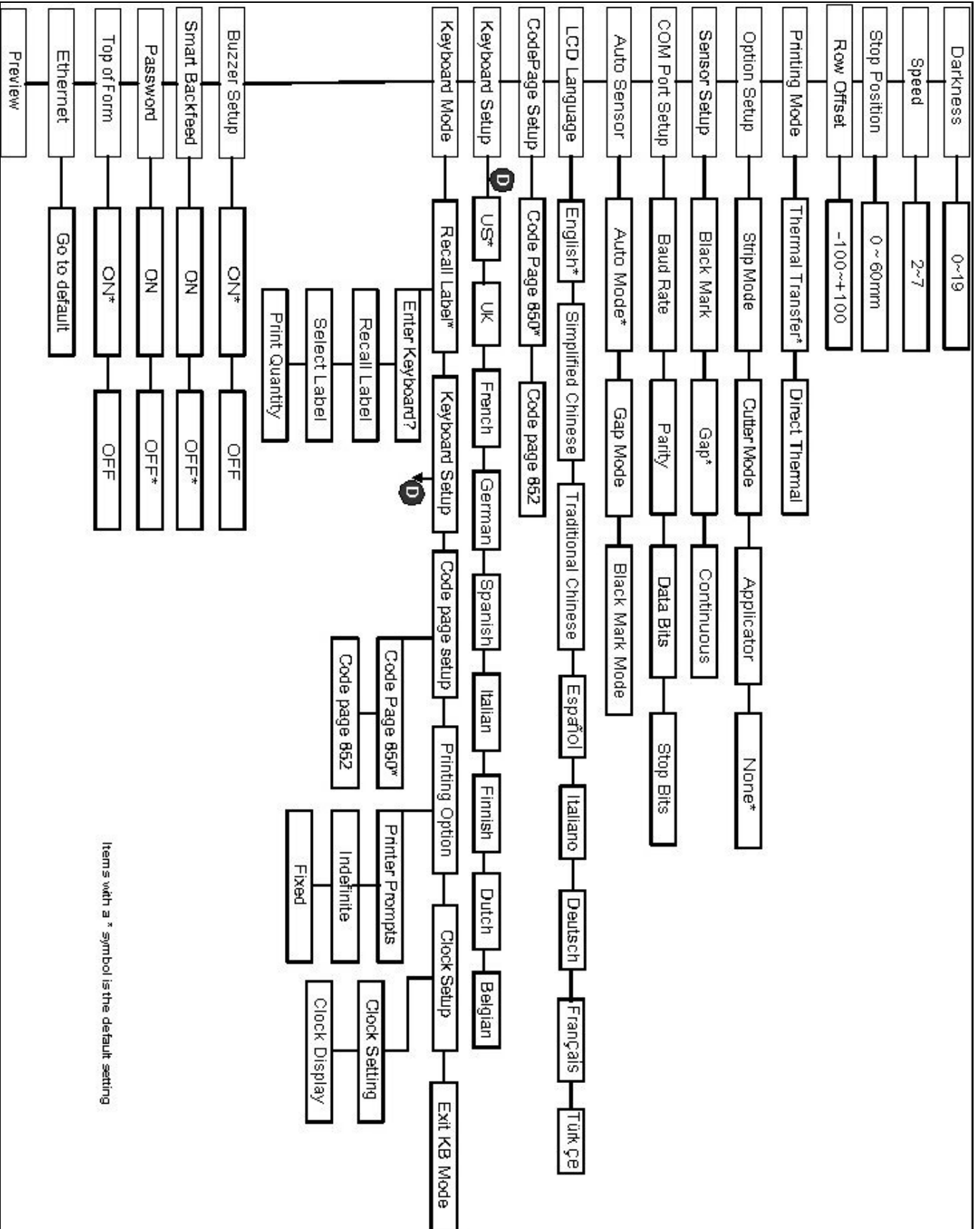

Items with a * symbol is the default setting

7. Loading Media

Ribbon Installation

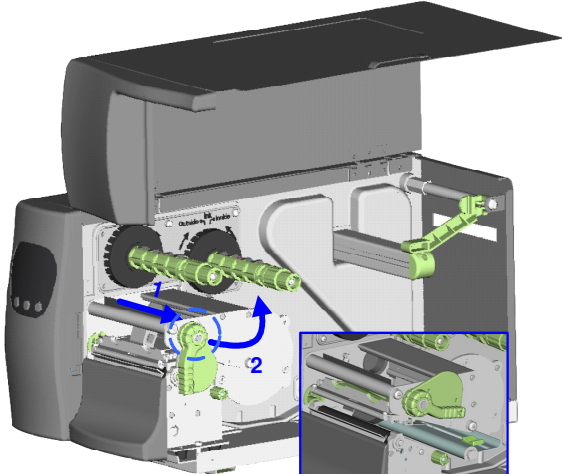
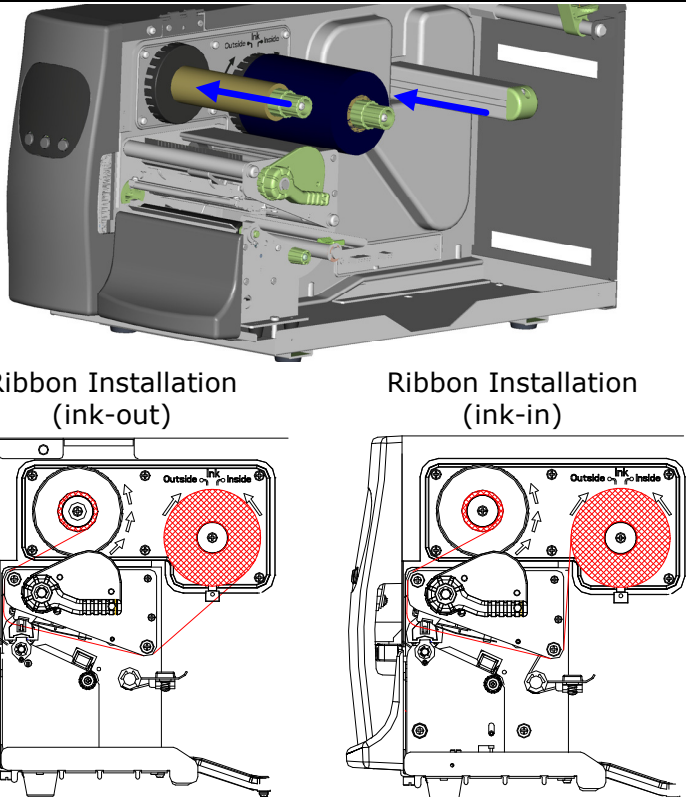
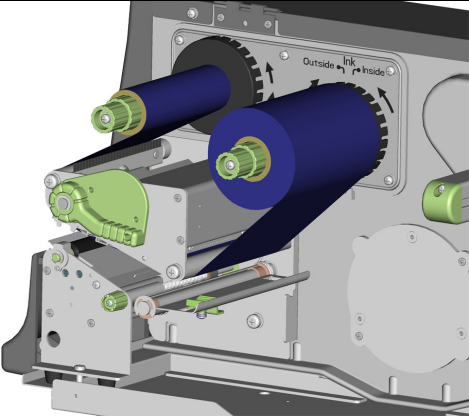
<ol style="list-style-type: none">1. Open the Printer's top cover.2. Pull the Printhead Lever out and rotate it upward to the right (counterclockwise) to open the Thermal Printhead.	
<ol style="list-style-type: none">3. Place the new ribbon roll onto the Ribbon Supply Shaft and place the empty ribbon core onto the Ribbon Rewind Shaft.4. The figure to the right shows two different installation methods. One is for ink-in ribbon and one for ink-out ribbon.5. Feed the ribbon from the Ribbon Supply Shaft Rod under the Printhead. Be sure that the ribbon is not fed under the Moveable Sensor.	
<ol style="list-style-type: none">6. Attach the end of the ribbon to the empty ribbon core using adhesive tape or part of a label.7. Rotate the Printhead Lever clockwise back to its original position making sure it snaps into place.8. Close the top cover to complete the ribbon installation.	

Label Installation

1. Open the Printer's top cover.
2. Pull the Printhead Lever out and rotate it upward to the right (counterclockwise) to open the Printhead.

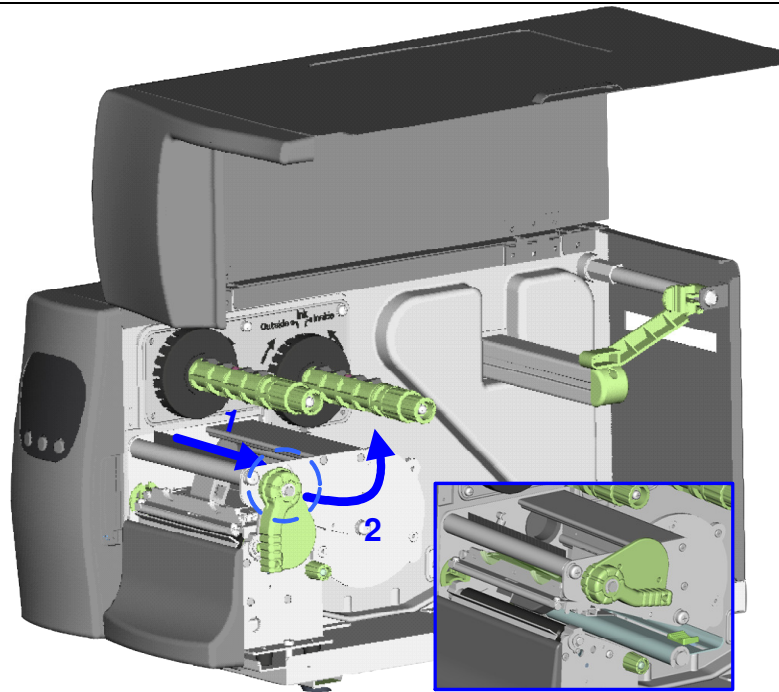

3. Pull the Label Alignment Guide in the direction as the blue arrow 1 indicates.
4. Rotate the Label Supply Guide upward as the blue arrow 2 indicates.

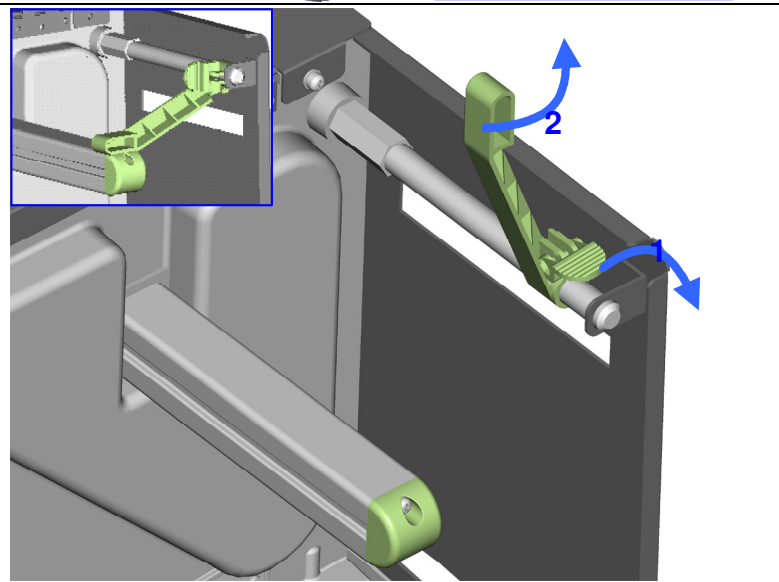

5. Slide the roll of label stock onto the Label Roll Bar all the way back to the Printer's inner wall.
6. Slide the Label Supply Guide in until it rests against the label stock. Avoid pushing the Guide in too far or you will damage the edge of the label stock.

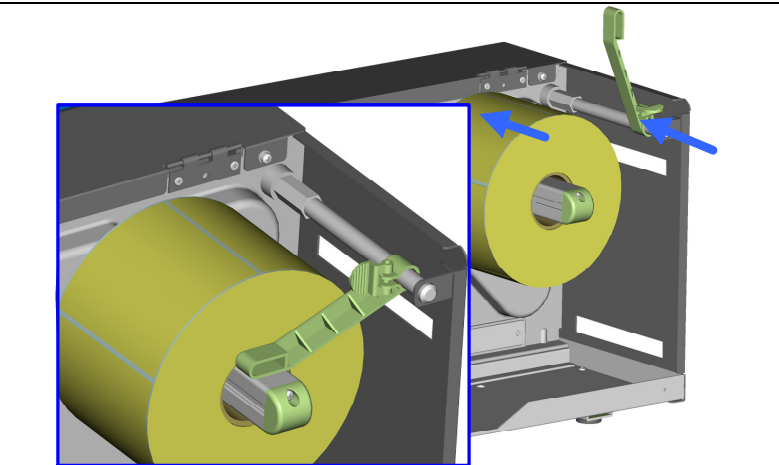

7. Feed the label stock as shown.

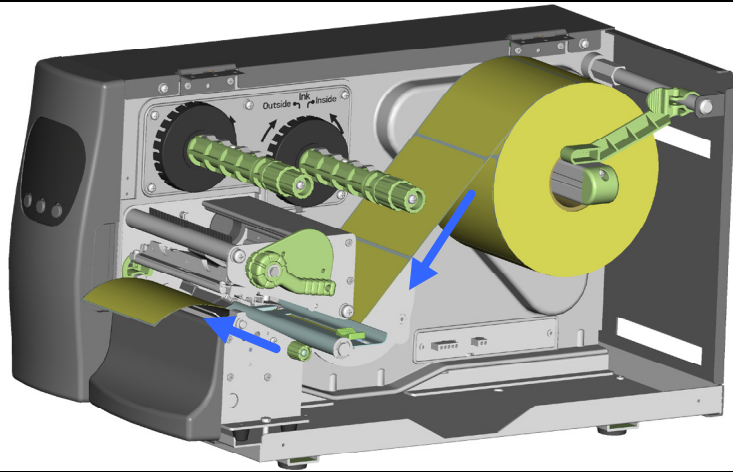

8. Feed the label stock through under the Moveable Sensor and feed it to the Tear Bar.

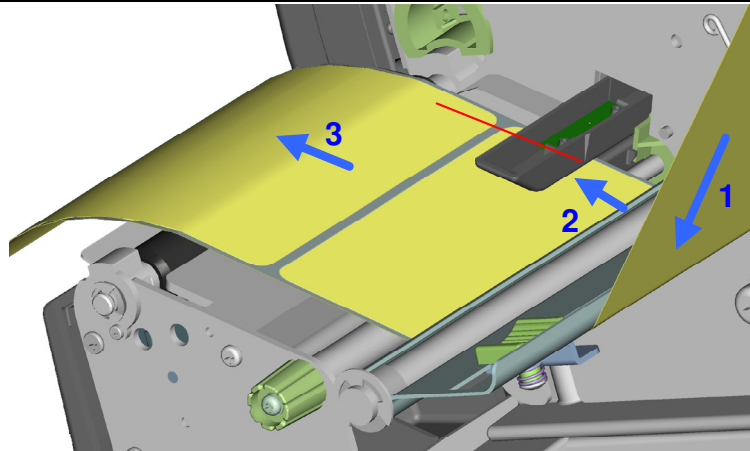

9. Position the edge of the label stock against the Printer's center wall and then position the Label Guide against the outside edge of the label stock.

10. Rotate the Printhead Lever back to its original position.

11. Close the top cover to complete the label installation.

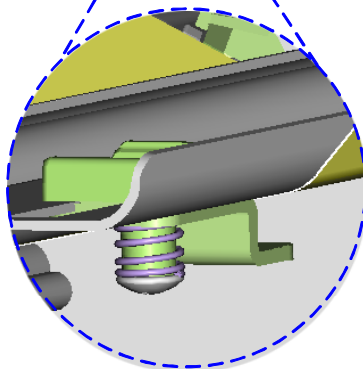
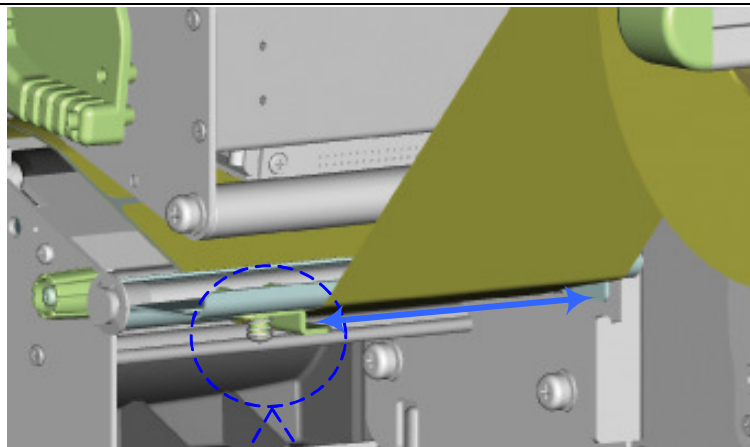

Activating the Stripper Sensor

The Stripper Sensor senses the presence of printed labels. With the Stripper Sensor activated, it is possible to operate the Printer in Tear-Off or Peel-Off (Strip-and-Peel) modes. See the "H-400 Internal Rewind Module Installation Instructions" section in this manual for more information about setting the Printer up for Strip-and-Peel.

To set up the Printer to operate in Tear-Off mode:

1. Press the Stripper Sensor to flip it open.
2. Correctly position the sensor and close the Top Cover of the Printer.
3. Turn the Stripper Sensor on in the Printer's Setup Mode.

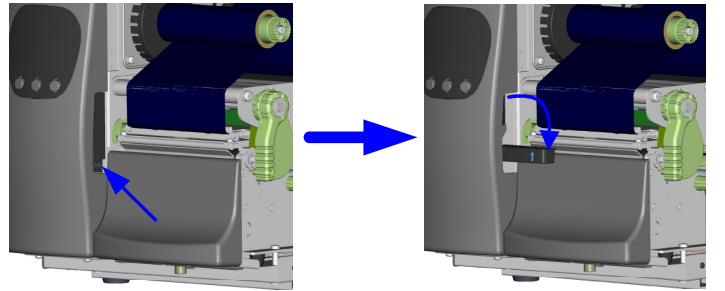

NOTICE!

When the Printer's Stripper Sensor is activated, it blocks part of the Tear-Off Bar. This can be a problem if the printed labels will be torn off after they are printed. In this case it is recommended to use perforated label stock to make tearing off the printed labels easier.

8. Installing the Printer's Optional Accessories

Many of the Optional Accessories for the H-400/H-600 Series Printers can be easily installed and configured in the field using only a Number 2 Phillips screwdriver. This section will provide a component list and installation instructions for these optional accessories.



CAUTION!
Make sure that the Printer's power switch is in the "O" or "Off" position before proceeding with the installation.



CAUTION!
Unplug the power cord from the Printer before performing any service on it. Failure to do so could result in personal injury or damage to the Printer!

H-400 Internal Rewind Module

1	Rewind Module	
2	Screws	
3	Rewind bracket	
4	U Shaped Clip	
<p><i>【Suggestion】 Liner : thickness 0.06mm +/- 10% weight 65g/m2 +/- 6%</i></p>		
<p>1. Open the Top Cover of the Printer and turn the Printer sideways.</p>		

2. Remove the Rewind Module Cover Plate.

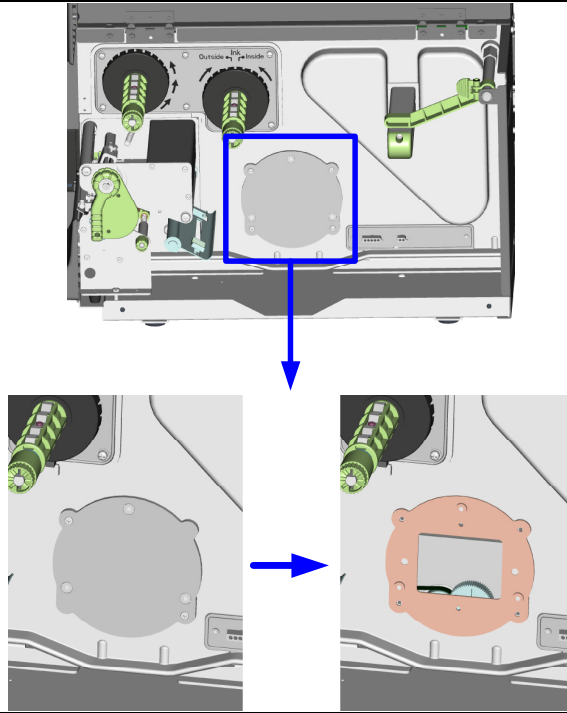

3. Remove the U Shaped Metal Clip (1) from the rewind shaft and then install the Internal Rewind module using the 4 supplied screws (2).

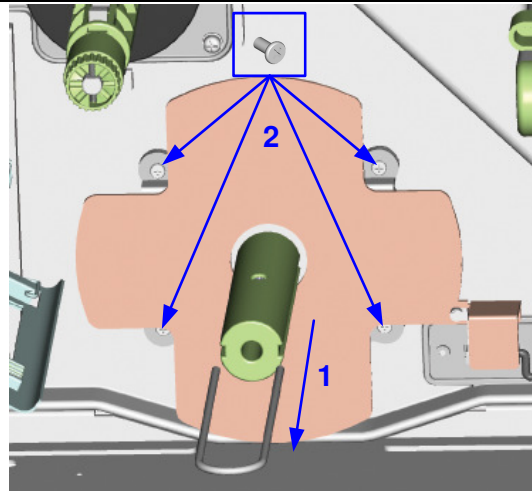

4. After installing the Internal Rewind Module, plug the cable connector onto the rewind control socket.

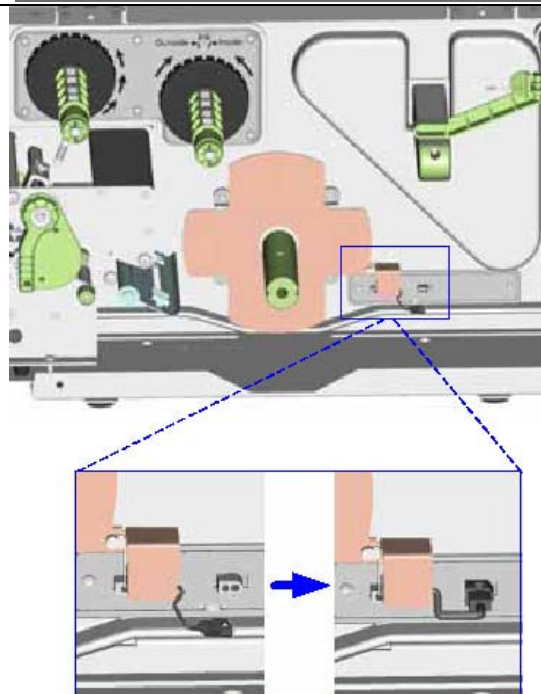

5. The Rewind Module Installation is complete.

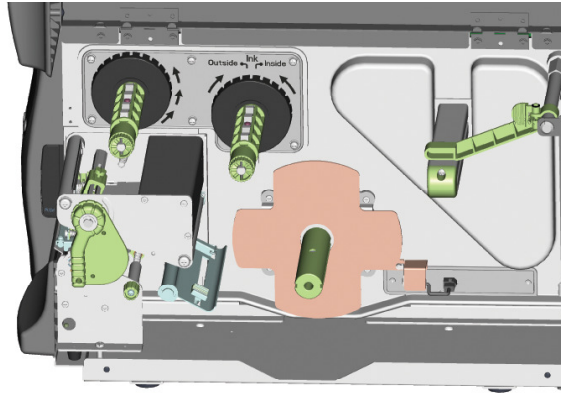

H-400 Series Strip-and-Peel Setup

1. Face the front of the printer and remove the Bottom Cover Screw.
2. Remove the Bottom Front Cover.

Note: Removing bottom cover is not mandatory but may make installation easier.

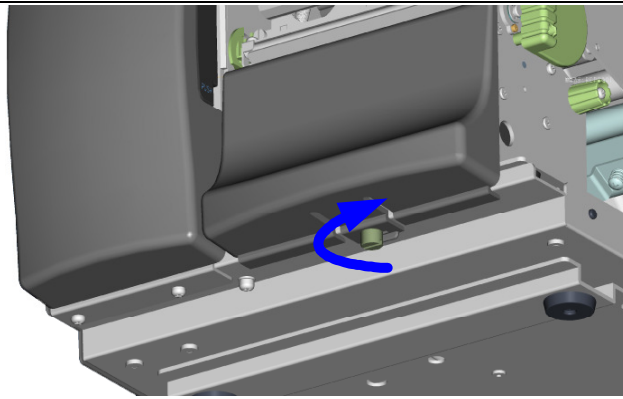

3. Pull the Printhead Lever out and rotate it upward to the right (counterclockwise) to open the Printhead.
4. Remove the U Shaped Metal Clip (3) from the rewind shaft.

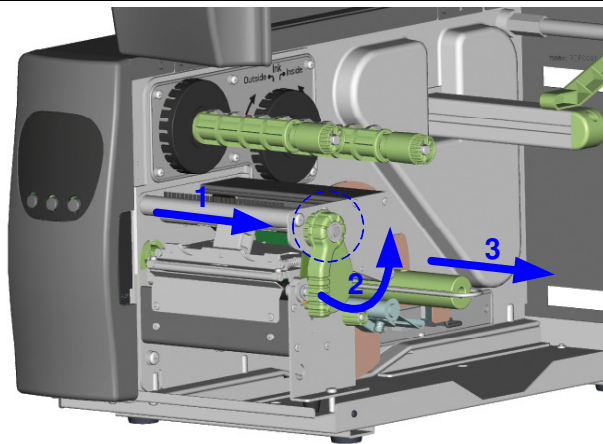

5. Install the label stock as shown. For more detailed instructions see the "Label Installation" instructions in this manual.



6. Peel off several labels to expose about 400mm (16") of liner. Then feed the liner between the Tear-Off Bar and the Bottom Front Cover.

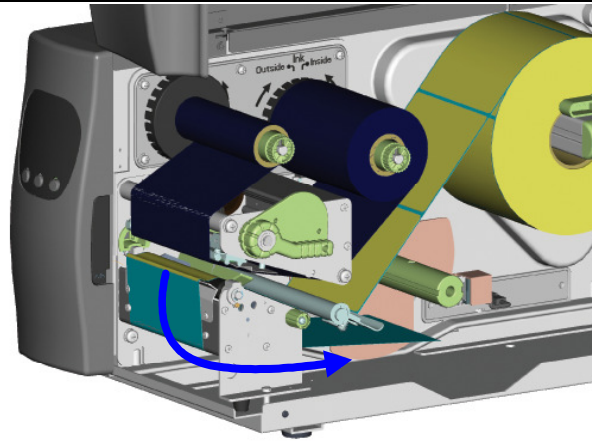

7. Wrap the liner around the Rewind Module (1), and use the U Shaped Metal Clip (2) to secure the liner.
8. Rotate the Printhead Lever back to its original position.

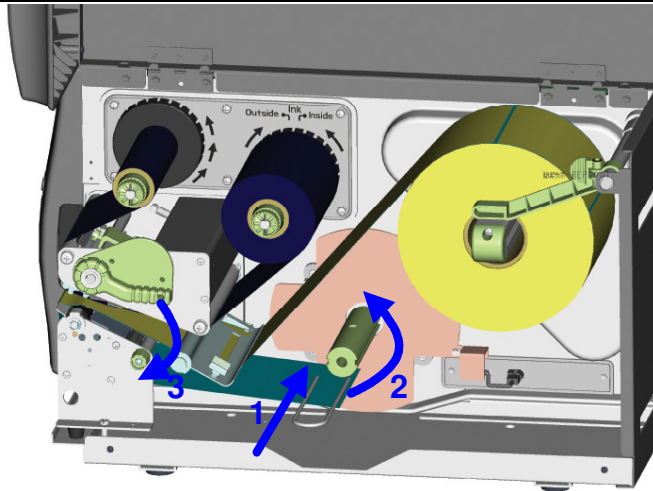

9. Replace the Bottom Front Cover and tighten the Bottom Cover Screw.

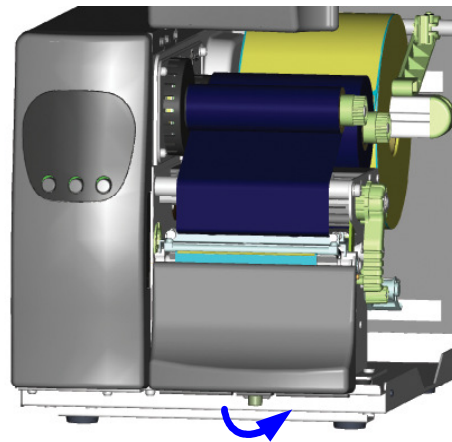

10. Press the Stripper Sensor to flip it open.
11. Correctly position the Sensor and close the Top Cover of the Printer.

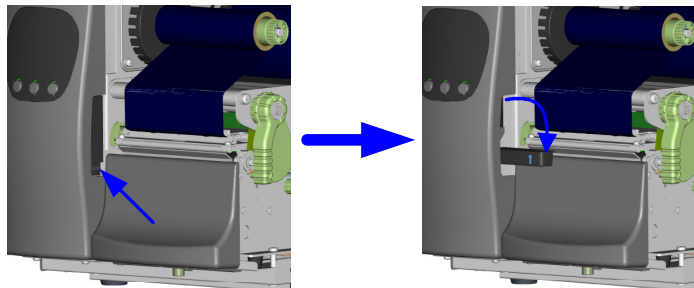

H-600 Series Stripper Module Installation

1	Stripper sensor Module
2	Locks
3	Screws

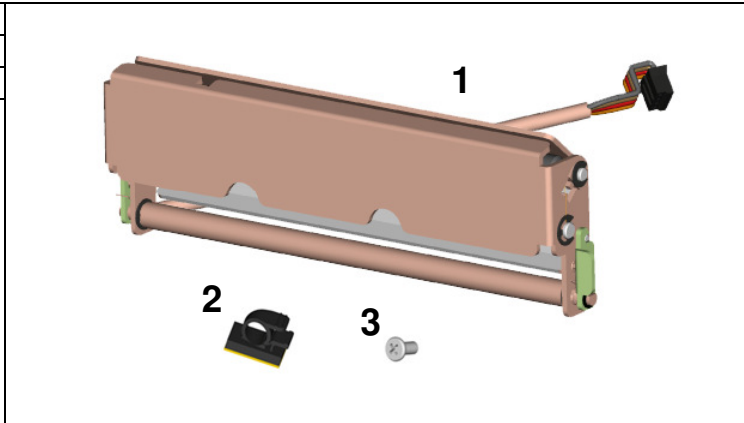

1. Face the front of the printer and remove the Bottom Cover Screw.
2. Remove the Bottom Front Cover.

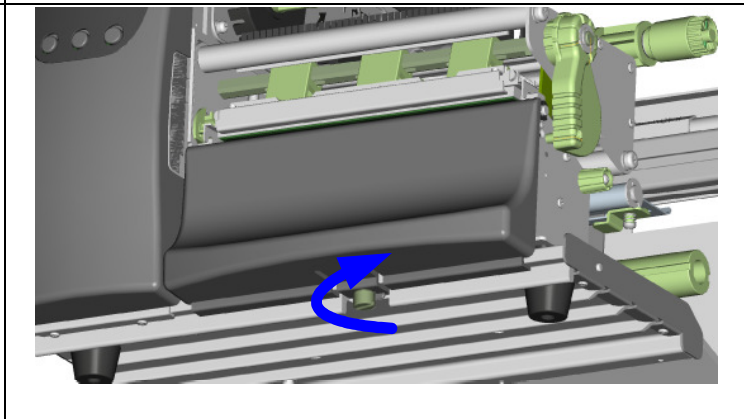

3. Remove the two screws in the front of the printer to remove the Tear Off Bar.

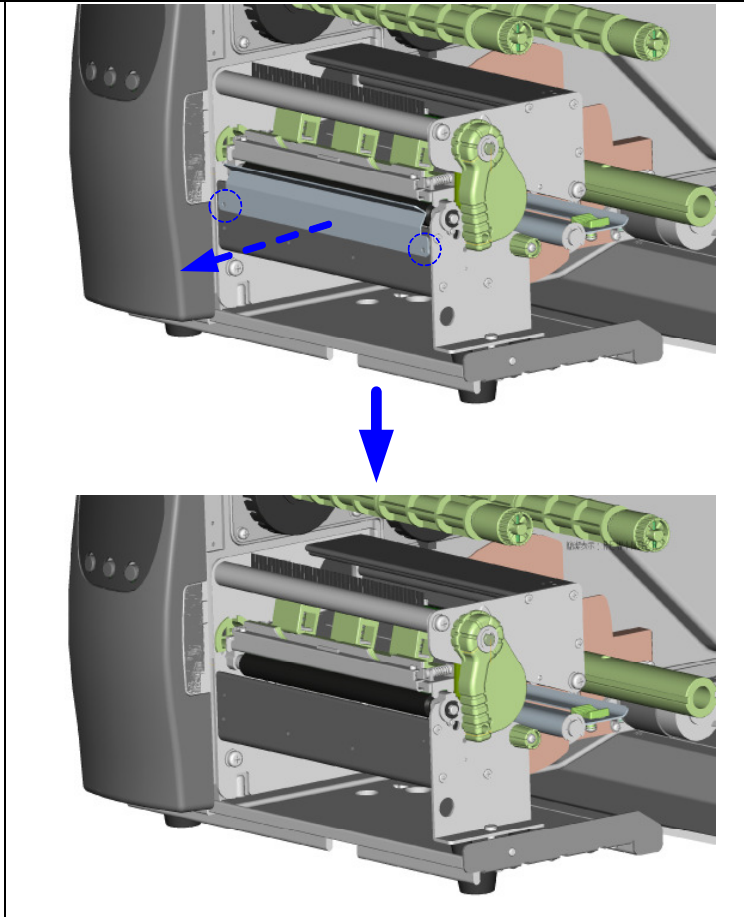

4. Secure the Stripper Module to the printer.

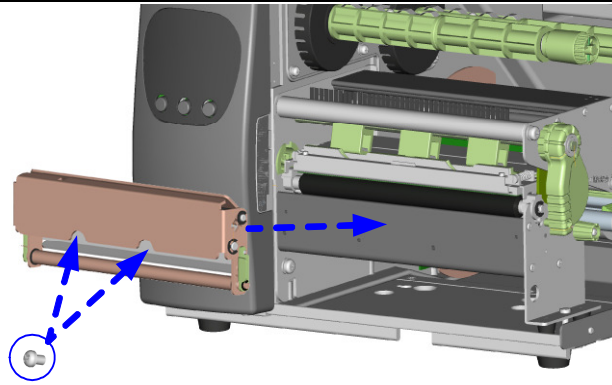

5. Plug the stripper cable into the stripper connector at the bottom of the Rewind Module.

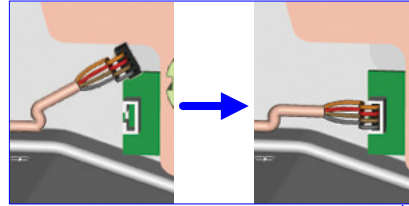

6. Insert the cable into the locks. Peel the backing off the locks and then secure them to the bottom plate.

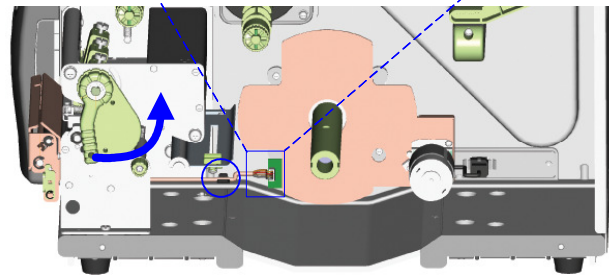

7. Pull the Printhead lever out and rotate it upward to the right.

8. Loosen the lock bar (as shown with blue arrow 1) of the stripper.
9. Rotate the Stripper Module downward to open it.

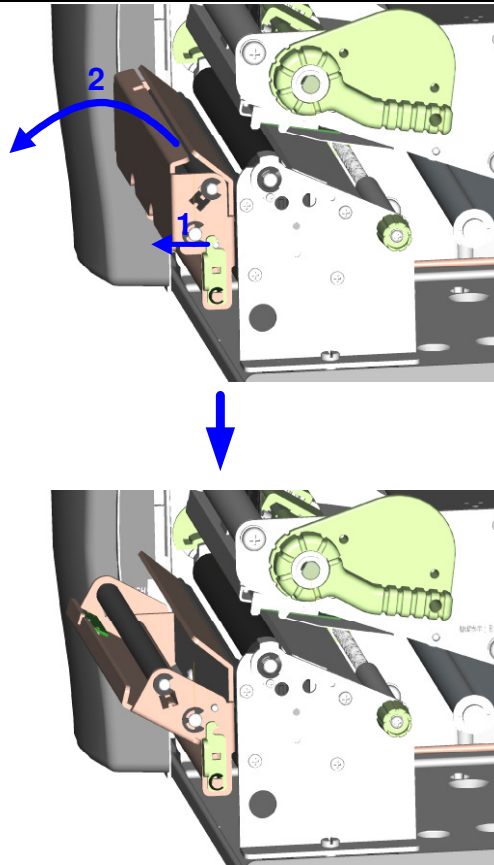

10. Peel off several labels to expose about 400mm (16") of liner. Then feed the liner through the Stripper Module.

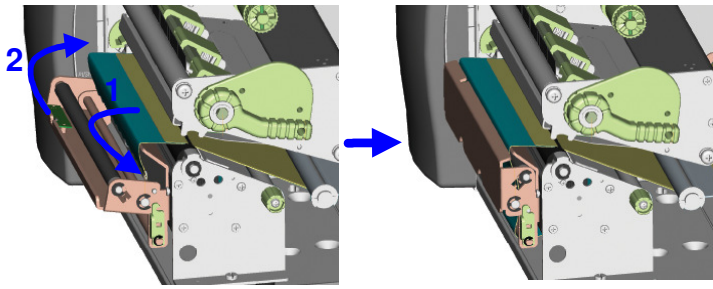

11. Close the Stripper Module and secure the lock bar.

12. Wrap the liner around the Rewind Module (1), and use the U Shaped Metal Clip (2) to secure the liner.

13. Rotate the Printhead Lever back to its original position.

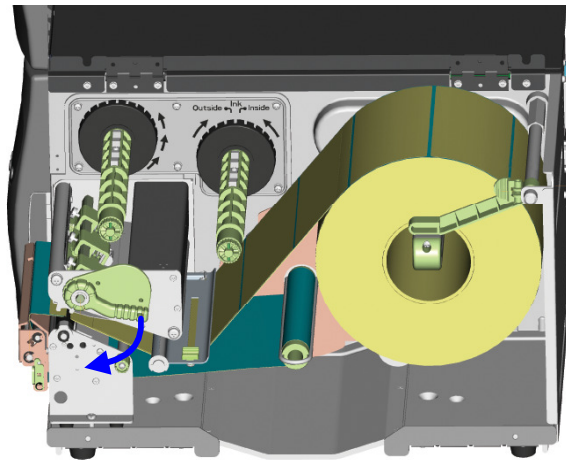
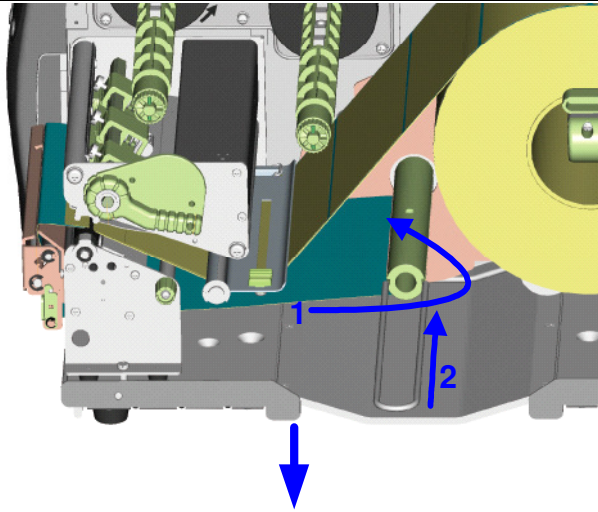

14. Close the Top Cover to complete the Stripper Module installation.

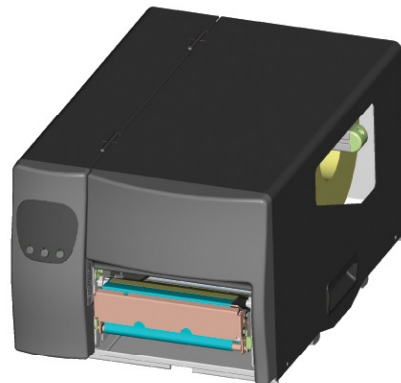

Rewind Bracket Installation and Use

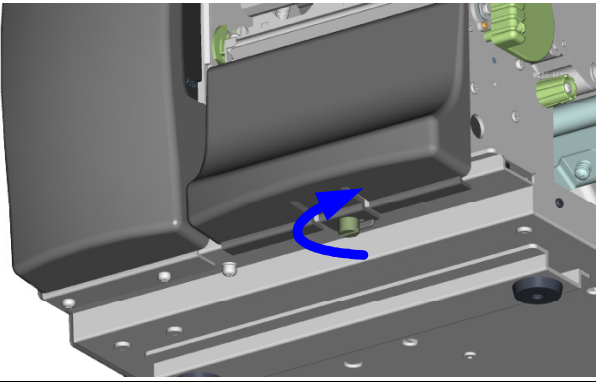
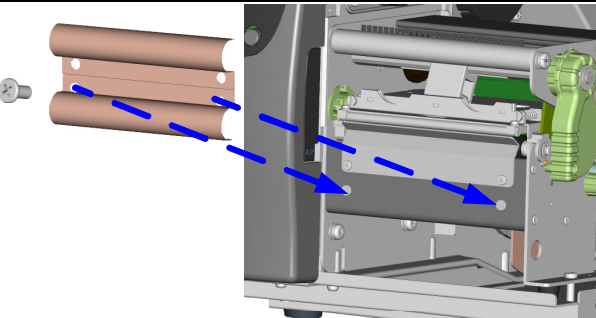
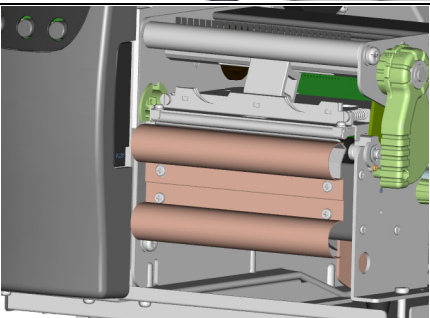
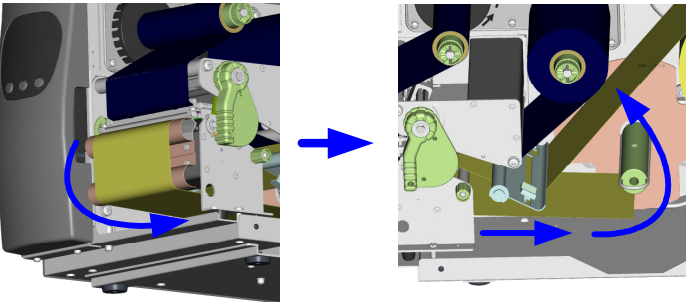
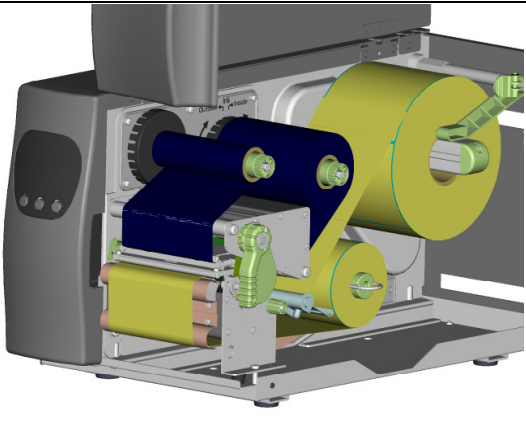
<ol style="list-style-type: none">1. Face the front of the Printer and remove the Bottom Cover Screw.2. Remove the Bottom Front Cover.	 A 3D cutaway diagram of the printer's base. A blue arrow points to a screw being removed from the bottom cover. Another blue arrow points to the bottom front cover being lifted away from the printer's chassis.
<ol style="list-style-type: none">3. Mount the Label Rewind Bracket onto the Printhead Mechanism and secure with the screws provided.	 A 3D cutaway diagram showing a brown, U-shaped metal bracket being aligned with the printhead mechanism. Blue dashed arrows indicate the path of the bracket's legs as they are inserted into the printer's frame. A screw is shown being inserted into the bracket to secure it.
<ol style="list-style-type: none">4. The Label Rewind Bracket is now installed. Install the label stock.	 A 3D cutaway diagram of the printer with the label rewind bracket installed. A roll of yellow label stock is being fed into the printer from the left, passing through the printhead mechanism and around the newly installed bracket.
<ol style="list-style-type: none">5. Feed the label stock through the Printhead Mechanism and around the Label Rewind Bracket.6. Wrap the liner around the Rewind Module and use the U Shaped Metal Clip to secure the liner.	 Two 3D cutaway diagrams showing the label stock being fed through the printer. The left diagram shows the stock entering the printhead. The right diagram shows the stock being wrapped around a blue rewind module. A blue U-shaped metal clip is shown being used to secure the liner of the rewind module.
<ol style="list-style-type: none">7. Close the top cover to complete Label Rewind Bracket installation.	 A 3D cutaway diagram of the printer with the top cover closed. The label stock is now fully installed and ready for use. The label rewind bracket and rewind module are visible in their final positions.

Cutter Installation (H-400 Series is shown the H-600 is similar)

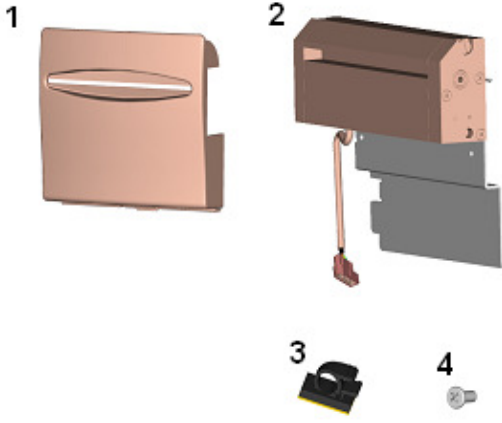
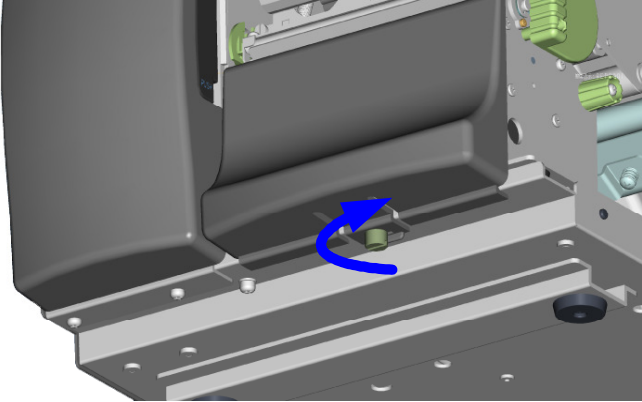
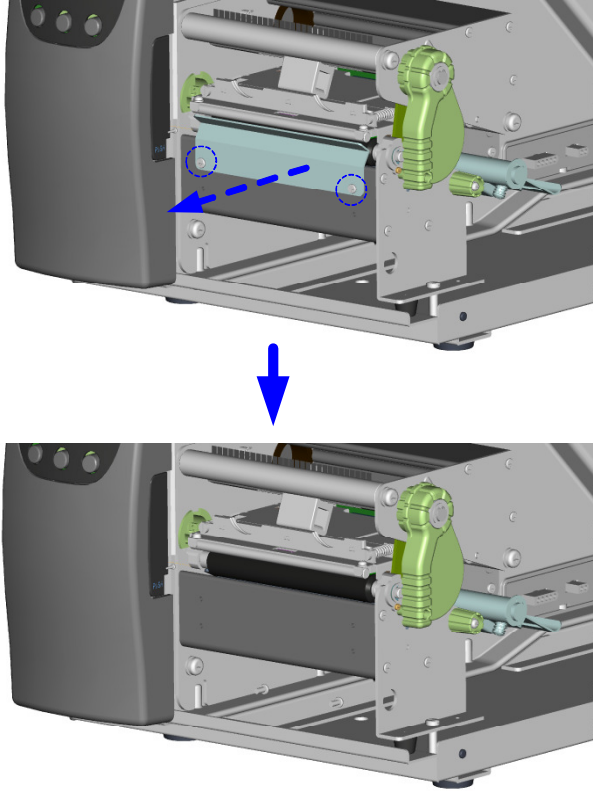
1	Cutter Cover	
2	Cutter	
3	Locks	
4	Screws	
		<p>1. Face the front of the Printer and remove the Bottom Cover Screw.</p> <p>2. Remove the Bottom Front Cover.</p> 
<p>3. Remove the two screws in the front of the Printer to remove the Tear Off Bar.</p>		

4. Secure the Cutter to the Printer with two screws.

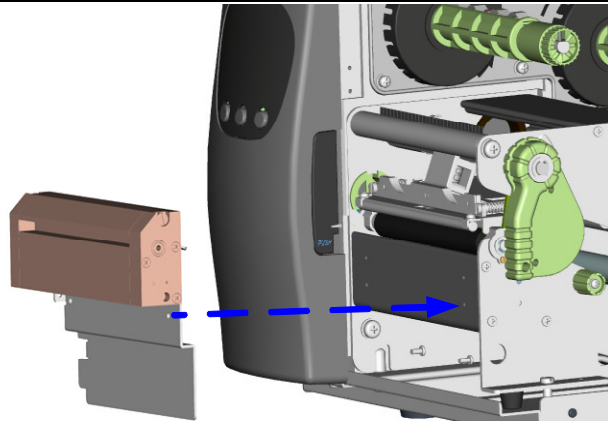

5. Plug the Cutter cable into the cutter connector on the center wall.

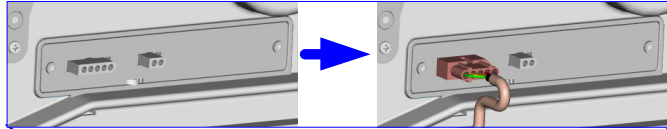

6. Insert the cable into the locks. Peel the backing off the locks and then secure them to the bottom plate

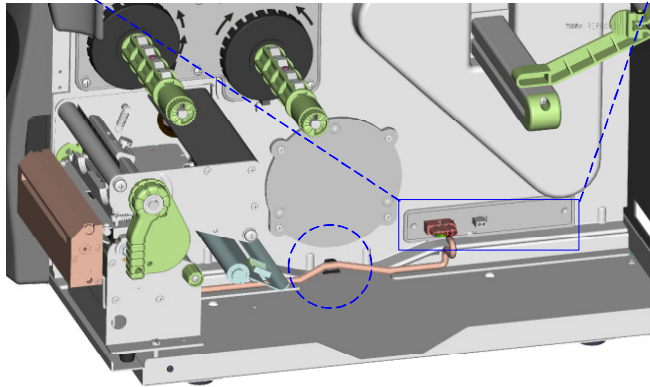

7. Hang the Cutter Cover on the Cutter and then tighten the bottom cover screw.

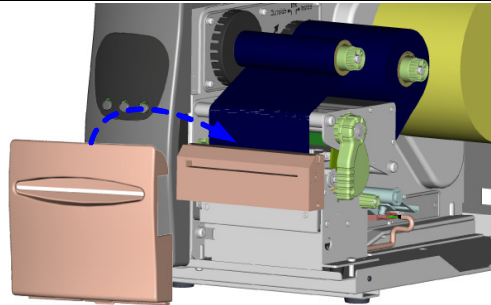

8. Load the media into the Printer and close the Top Cover to complete the Cutter installation.

The minimum forms length for cutting should be at least 35mm (1.38”).

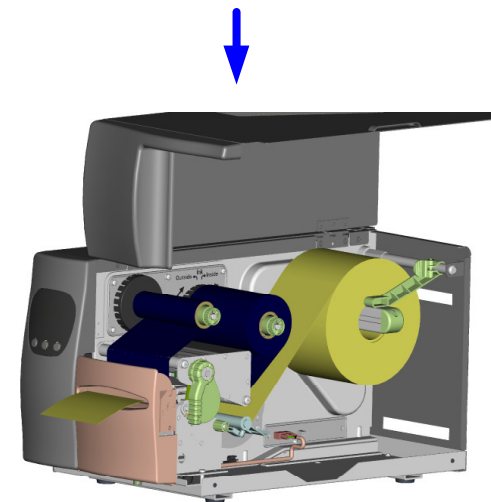

9. Using the Printer with a PS/2 Keyboard

Entering/Exiting Keyboard Mode



NOTICE!

The location of keys on a keyboard can vary based on the language! Before connecting a keyboard please set the correct Keyboard Language in Setup. (See the section 'Menu items and available Options in Setting Mode'.)

The PS/2 interface can be used to connect a keyboard to the Printer for stand-alone printing without a computer attached. Once a format has been selected from memory, the LCD will prompt the user for the format's variable data and quantity to print. The user can use the keyboard to make these selections and enter the format's variable data. The LCD provides the user with feedback by displaying on the screen what has been typed. To enter Keyboard Mode:

1. Plug the connecting cable of a standard PS/2 keyboard into the PS/2 interface port on the back of Printer.
2. The Printer will sense that a keyboard is present and will display "Enter Keyboard Mode [y/n]" on the LCD.
3. Press the "Y" key on the keyboard to enter Keyboard Mode.

While in Keyboard Mode you can press the **ESC** key to go back to the previous menu. To exit Keyboard Mode, press the **ESC** key until the LCD displays "Exit Keyboard Mode [y/n]". Press the "Y" key on the keyboard to exit Keyboard Mode or press the "N" key on the keyboard to continue in Keyboard Mode.



NOTICE!

You can also exit Keyboard Mode by selecting "Exit KB Mode" from the Keyboard Mode menu selections on the front panel.

To re-enter Keyboard Mode, simply press the F1 key or cycle the power on the Printer with the keyboard still connected to the Printer's PS/2 port and press the "Y" key on the keyboard when the Printer displays "Enter Keyboard Mode [y/n]" on the LCD Screen.



NOTE

If the Printer is on and the keyboard is already connected you can enter Keyboard Mode by pressing the F1 key on the keyboard.



NOTE

You can feed a blank label while the Printer is in Keyboard Mode by pressing the F2 key on the keyboard.

Menu Items and Options available in Keyboard Mode

Once the Printer is in Keyboard Mode, the user will be presented with a menu. The user can navigate through the menu by using the Up and Down arrow keys on the keyboard. Menu selections are made by pressing the Enter key on the keyboard while the item is displayed. The menu items and their functions are as follows:



NOTICE!

The "Keyboard Setup" and "Code Page Setup" options are also in the Printer's Setting Mode menu. The values displayed for these two options will be taken from the Setting Menu and any changes made to these options will be reflected in the Setup Mode menu. (See the section 'Menu items and available Options in Setting Mode'.)

Recall Label	Allows the user to select a format to be printed from a list of all downloaded formats. Use the Up and Down arrows on the keyboard or press the first character of the format name on the keyboard to browse the list of stored formats and press the Enter key to select a format. The user will be prompted for any variable data and a quantity to print. If no formats have been downloaded the user will be presented with the message "No label format in memory..."
Keyboard Setup	US International United Kingdom French German Spanish Italian Finnish Dutch Belgian
Code Page Setup	Code Page 850, Code Page 852
Clock Setup	<i>Note: A keyboard must be used to set the time and date.</i> Allows user to display Printer time or set Hours, Minutes, Seconds, Month, Date, Year and Day. When setting the clock, use the Enter key on the keyboard to move through the prompts. Use the Backspace key on the keyboard to delete the current setting. Then type in a new setting.
Exit KB Mode	Exits Keyboard Mode and puts the Printer back into Standby Mode.

Downloading to the Flash Memory using EASYLABEL

EASYLABEL formats can be downloaded to the Printer's Flash Memory (or CompactFlash card) and the user will be able to print labels from the Printer without a PC attached.



NOTICE!

The "Use Memory Card" Printer Configuration option in EASYLABEL determines if the Printer's Flash memory or a CompactFlash card is used to store formats. If it is set to 'No' then EASYLABEL will use the Printer's internal Flash memory. If it is set to 'Yes' then EASYLABEL will use the CompactFlash Card. The "Use Memory Card" is in the Printer Configuration on the 'Advanced' tab. When downloading a database to the Printer memory, there is a 98 character limit for each database field.

When creating a format in EASYLABEL, be sure the "Memory Card Download" option in the Format Specifications page is set to YES.

Be sure the printer is attached to the PC only through the serial port or the USB port when formats are being sent to the printer memory or when there are formats in the printer memory.

After creating the format(s) that need to be sent to the Printer, there are two ways to download formats to the Printer.

Downloading a single format:

1. At the Edit screen of EASYLABEL click the Printer icon or click File | Print Batch of Formats from the menu.
2. The Print Request screen will appear. Click Cancel.
3. Click the Download Format to Memory Card icon or click Tools | Download Format to Memory Card.
4. A "Download Format to Memory Card" Window will appear where the user can make choices for downloading the format. After the selections have been made, click the OK button.
5. "Data Receiving" will be displayed on the LCD screen of the Printer.
6. A "Finished downloading format to the memory card" message box will be displayed after the download is complete. Click the OK button.

Downloading multiple formats:

1. From EASYLABEL click File | Download Multiple Formats.
2. From the Browse Window select all formats that need to be downloaded to the Flash memory and click the Open button.
3. Choose and click Yes or No at the Auto-Name Formats message box.
4. A "Download Format to Memory Card" Window will appear where the user can make choices for downloading the format. After the selections have been made, click the OK button.
5. "Data Receiving" will be displayed on the LCD screen of the Printer.
6. A "Finished downloading format to the memory card" message box will be displayed after the download is complete. Click the OK button.

Appendix A. Communication Interfaces

Parallel Interface

The Printers are equipped with a 36-pin Parallel interface connector. Any standard IBM PC compatible parallel cable can be used to connect to your Printer. In the event of any difficulties, the table listed below can be used to obtain a suitable cable.

PIN NO.	FUNCTION	TRANSMITTER
1	Strobe	Host / Printer
2-9	Data 0-7	Host
10	Acknowledge	Printer
11	Busy	Printer
12	Paper Empty	Printer
13	Select	Printer
14	Auto-Linefeed	Host / Printer
15	N/C	
16	Signal Ground	
17	Chassis Ground	
18	+5V DC	
19-30	Signal Ground	Host
31	Initialize	Host / Printer
32	Fault	Printer
33	Signal Ground	
34-35	N/C	
36	Select-in	Host / Printer

Serial Interface

The Printers are equipped with a 9-pin SUB-D connector to be used as a Serial interface.



NOTICE!

Make sure that the "COM Port Setup Options" in the Printer's front panel are configured the same as the software you will be using with the Printer.

Connector Type: DB9 female, pin assignment is as follows:

PIN NO.	1	2	3	4	5	6	7	8*	9
FUNCTION	+5 V	TXD	RXD	N/C	GND	N/C	CTS	RTS	N/C

**Flow Control Line*

Serial interface from PC to Printer

PC		Printer
---	1	1 +5V
RXD	2	2 TXD
TXD	3	3 RXD
DTR	4	4 N/C
GND	5	5 GND
DSR	6	6 N/C
RTS	7	7 CTS
CTS	8	8 RTS
---	9	9 N/C

USB Interface

The Printer is equipped with a Type B USB connector that can be connected to any compatible USB port.

PIN NO.	1	2	3	4
FUNCTION	USBVCC	D-	D+	GND

PS/2 Interface

The PS/2 interface can be used to connect a keyboard to the Printer for stand-alone printing without a computer attached. (See section 9. Using the Printer with a PS/2 Keyboard.)

PS/2 interface from keyboard to Printer

PC			Printer
DATA	1	1	DATA
N/C	2	2	N/C
GND	3	3	GND
VCC	4	4	VCC
CLOCK	5	5	CLOCK
N/C	6	6	N/C

Optional Applicator Interface

The applicator interface provides a means of communications between an applicator and the H-400/H-600 Series Printers.

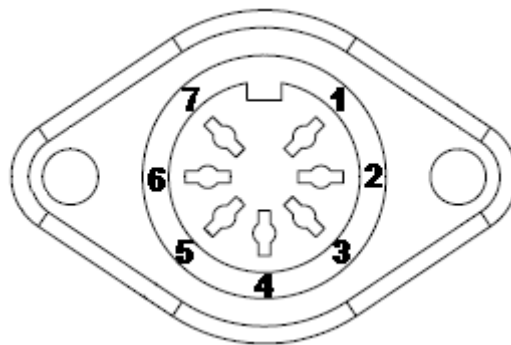

PIN NO.	1	2	3	4	5	6	7
FUNCTION	Print Signal	+5 V	Printer Error Signal	+24 V	Printed Signal	Printing Signal	Ground

Appendix B. Error Messages / Troubleshooting

Self-Test

The Self-Test function in the Printer will help the user to troubleshoot whether the Printer is operating normally. In the Self-Test Mode, the Printer will print out a test sample each time the FEED Key is pressed. To stop the Self-Test procedure simply power off the Printer. Below are the Self-Test procedures:

To perform a Self Test:

1. Turn the Printer Off.
2. Press and hold the FEED Key.
3. Turn the Printer On while still holding the FEED Key down.
4. Release the FEED Key after hearing 3 beeps.

After about 1 second the Printer will print the Test Label and the LCD will display "Self Test". This means the Printer is operating normally. Simply cycle the power on the Printer to exit the Self Test.

- 1 HXXXX : X.XXX
- 2 Serial port :96,N,8,1
- 3 [Test Pattern]
- 4 1 DRAM installed
- 5 Image buffer size : 4010K
- 6 000 FORM(S) IN MEMORY
- 7 000 GRAPHIC (S) IN MEMORY
- 8 000 FONT(S) IN MEMORY
- 9 000 ASIAN FONT(S) IN MEMORY
- 10 000 DATABASE(S) IN MEMORY
- 11 000 TTF(S) IN MEMORY
- 12 769K BYTES FREE MEMORY
- 13 ^S6 ^H8 ^R000 ~R200
- 14 ^W100 ^L100,3
- 15 Option : ^D0 ^O0 ^AD
- 16 Gap Sensor AD : 129 162 195 (3)
- 17 Code Page: 850
- 18 Keyboard Layout : US-International
- 19 Top Of Form: OFF
- 20 Max Print Length (mm): XXXX

1. Model & Firmware Version
2. Serial port settings
3. Test pattern
4. Number of DRAM installed
5. Image buffer size
6. Number of forms
7. Number of graphics
8. Number of fonts
9. Number of Asian fonts
10. Number of Databases
11. Number of TrueType Fonts
12. Free memory size
13. Speed, Heat, Reference Point, Print Direction
14. Label Width, Label Length, Gap Length
15. Options and Print Mode*
16. Gap sensor AD
17. Code Page
18. Keyboard Layout
19. Top Of Form Option
20. Maximum Print Length in millimeters

- *Option**
- ^D0- Cutter Disabled
 - ^D1- Cutter Enabled
 - ^O0- Stripper Disabled
 - ^O1- Stripper Enabled
 - ^O2- Applicator Mode
- Print Mode**
- ^AT- Thermal Transfer
 - ^AD- Direct Thermal

Dump Mode

The Printer's Dump Mode provides the ability to print the command sequences received by the Printer instead of executing them. Dump Mode is very useful as a troubleshooting tool when the label settings and the print results do not match, and can be used to check for errors in data transmission between the Printer and the PC. Examining the Dump Mode print out will confirm whether or not the correct commands were received.

To enter Dump Mode:

1. Turn the Printer Off.
2. Press and hold the FEED Key.
3. Turn the Printer On while still holding the FEED Key down.
4. The Printer will beep three times. Continue to hold the FEED Key down; the Printer will beep one more time.
5. When the LCD shows the message "DUMP MODE BEGIN", release the FEED Key. The Printer will print "DUMP MODE BEGIN". The Printer is now in Dump Mode.
6. Send commands to the Printer and check to see if the commands printed are the same commands sent by your application.
7. Press the FEED Key to exit Dump Mode. The Printer will print "OUT OF DUMP MODE" to confirm that it is no longer in Dump Mode.

LCD Error Messages and Descriptions



Blinking
Quickly



Blinking
Slowly



Steady

LCD Message	LED Lights		Beep	Description	Solution
	Ribbon	Media			
Printhead is opened			4	The Printhead not firmly locked in place.	Re-open the Printhead and make sure it closes tightly.
Entering the Cooling Process				Printhead temperature is too high.	Printer goes back to standby mode after cooling.
Out of ribbon or check ribbon sensor			3	No ribbon is installed and using Direct Thermal stock.	Make sure the Printer is in Direct Thermal mode.
				The ribbon is used up or the Ribbon Supply Shaft is not moving.	Replace with new ribbon roll.
Out of media or check media gap sensor			1	The moveable sensor is unable to detect paper.	Make sure the movable sensor mark is at the correct position. If the sensor is still unable to detect the paper, then go through the Auto Sensing steps again.
				The label stock is used up or label sensor cannot detect paper.	Replace with new roll of labels. If the moveable sensor is still not able to detect the paper, then go through the Auto Sensing steps again.
Check paper setting			1	Improper paper feed.	Possible causes: <ol style="list-style-type: none"> Media falling into the gap behind the platen roller. Can't find label gap/black mark. Perform Auto Sensing procedure. Black mark paper out.
CF Card not found			2	CF Card is not installed or installed incorrectly.	Install the CF Card correctly.
Memory Full			2	Memory is full.	Delete unnecessary data in the memory.
Rewinder Full			2	The Rewind is full.	Remove the labels from the Rewind.
Filename cannot be found			2	Cannot find the file.	Use "~X4" command to print out all the files and check whether the file exists and if the name is correct.
Filename repeated			2	Another file with this name exists.	Change the file name and download again.



NOTICE!

The Printer repeats all warning beeps. For example when the Printer's Printhead is opened, the Printer will beep four times, pause, and then beep four more times.

Problems and Recommended Solutions

Problem	Recommended Solution
LCD shows no message after switching the Printer on.	<ul style="list-style-type: none"> ◆ Check the power cord.
LED light turns red (power/status) after printing stops.	<ul style="list-style-type: none"> ◆ Check for software setting or program command errors. ◆ Check if labels or ribbon is out and replace with suitable labels or ribbon. ◆ Check if label stock is jammed. ◆ Check if Printhead Mechanism is closed (Printhead is not positioned correctly). ◆ Check if sensor is blocked by paper/label. ◆ If Cutter is installed, check that it is working and working properly.
Printing started but nothing was printed on the label.	<ul style="list-style-type: none"> ◆ Check that the ribbon is installed with the inked side facing the label media. ◆ Select the correct Printer driver. ◆ Select the correct label stock and print mode.
The labels jammed when printing.	<ul style="list-style-type: none"> ◆ Clear the label jam and check that the Printhead is clean.
Only part of the label was printed.	<ul style="list-style-type: none"> ◆ Check if label or ribbon is stuck on the Printhead. ◆ Check if application software has errors. ◆ Check if start position setting has errors. ◆ Check if ribbon has wrinkles. ◆ Check if Ribbon Supply Shaft is creating friction with the platen roller. If the platen roller needs to be replaced, please contact your Reseller for more information. ◆ Check if power supply is within the voltage range.
Part of the label was not printed completely.	<ul style="list-style-type: none"> ◆ Check if Printhead is dirty. ◆ Use internal command "~T" to perform a Test Print and check if the Printhead can print across its entire width. ◆ Check the media quality.
Printout not in desired position.	<ul style="list-style-type: none"> ◆ Check if sensor is covered by paper or is dirty. ◆ Check if liner is suitable for use, please contact Reseller for more information. ◆ Check if label roll edge is aligned with Label Width Guide.
Labels are skipped while printing.	<ul style="list-style-type: none"> ◆ Check if error occurs on label height setting. ◆ Check if the sensor is covered by paper or is dirty.
Smudged or blurry printout.	<ul style="list-style-type: none"> ◆ Check print darkness setting. ◆ Check if Printhead is dirty.
The cutter did not cut straight	<ul style="list-style-type: none"> ◆ Check if label stock is installed correctly.
The cutter did not cut the label successfully.	<ul style="list-style-type: none"> ◆ Check if the label thickness exceeds 0.16mm (.006").
When using the Cutter the labels could not feed or abnormal cutting occurs.	<ul style="list-style-type: none"> ◆ Check if Cutter is installed properly. ◆ Check if Paper Feed Rods are sticky. ◆ Check that label is greater than 35mm (1.38") high so it can clear the Cutter.
The Stripper Sensor is not functioning correctly.	<ul style="list-style-type: none"> ◆ Check if Stripper Sensor is covered with dust. ◆ Check if labels are installed properly.

Appendix C. Maintenance and Adjustment

Thermal Printhead Cleaning



CAUTION!

The Printhead is the Most Fragile part of your Printer. Do NOT use sharp or hard objects to clean the Printhead. Do NOT touch the glass surface of the Printhead with your hand.



CAUTION!

During the print process the Printhead will become hot. Do NOT attempt to clean the Printhead until it has had time to cool.

Printing labels will cause dirt such as paper dust, particles of ink and label adhesive to accumulate on the Thermal Printhead. This can cause poor print quality and incomplete printouts. When this happens the Printhead must be cleaned:

1. Turn the Printer Off.
2. Open the Top Cover.
3. Pull the Printhead Lever out and rotate it upward to the right (counterclockwise) to open the Thermal Printhead.
4. Remove the label stock and ribbon from the Printer.
5. Clean the Printhead surface (see arrow) with a special cleaning pen or a cotton swab soaked in Isopropyl Alcohol.
6. Allow the Printhead to dry for 2-3 minutes before turning the Printer back on.

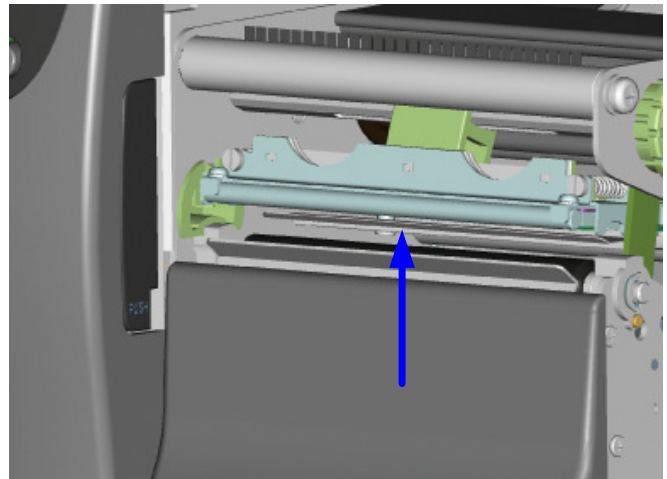

NOTICE!

To help keep the Printhead clean, the Top Cover of the Printer should be closed when printing. To ensure print quality and prolong Printhead life, do NOT use dusty or dirty print media in the Printer.



NOTICE!

Recommended cleaning intervals for the Thermal Printhead:
Direct Thermal Printing – Each time the label roll is changed.
Thermal Transfer Printing – Each time the ribbon is changed.

Printhead Module Installation / Removal Instructions

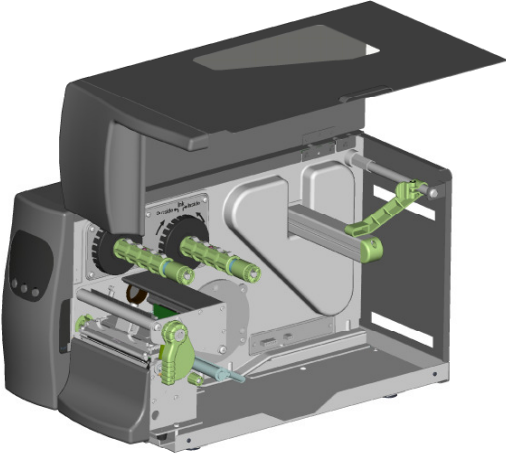
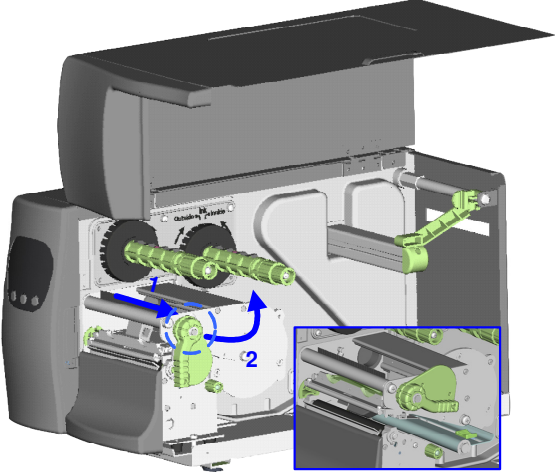
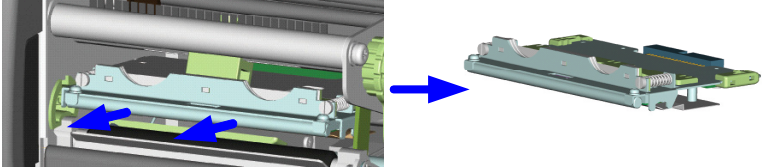
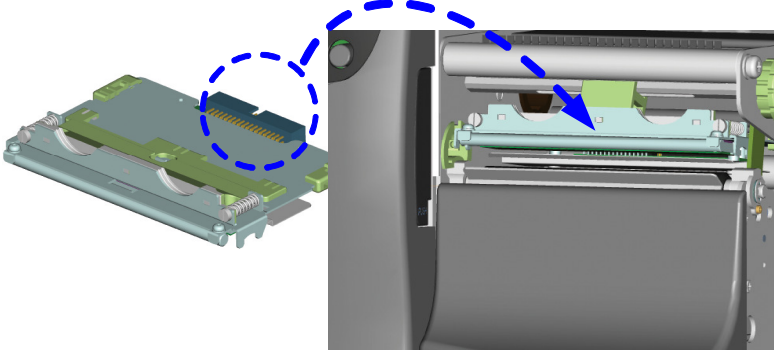
<p>1. Switch the Printer off and unplug it.</p>	
<p>2. Pull the Printhead Lever out and rotate it upward to the right (counterclockwise) to open the Printhead.</p>	
<p>3. Gently pull the Printhead assembly towards you.</p>	
<p>4. To replace the Printhead, line up the plug and side guides of the Printhead assembly and gently insert the Printhead back into its carriage.</p>	

Printhead Print Line Adjustment

When printing on stiff or thick paper, the Print Line needs to be moved forward (paper feed direction) in order to achieve better print quality.

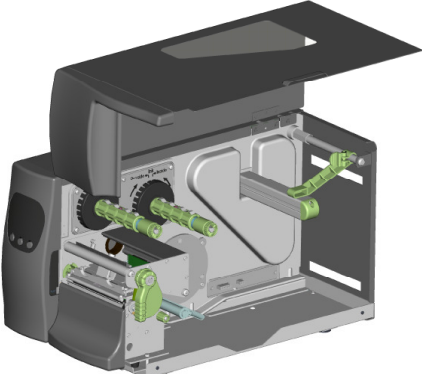
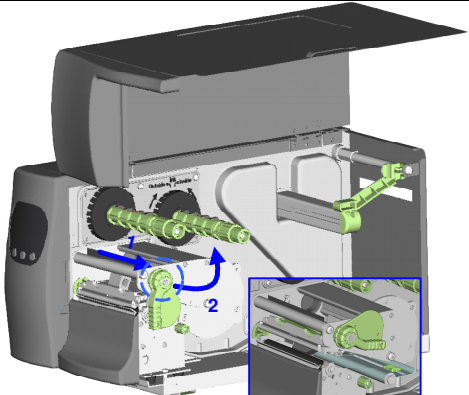
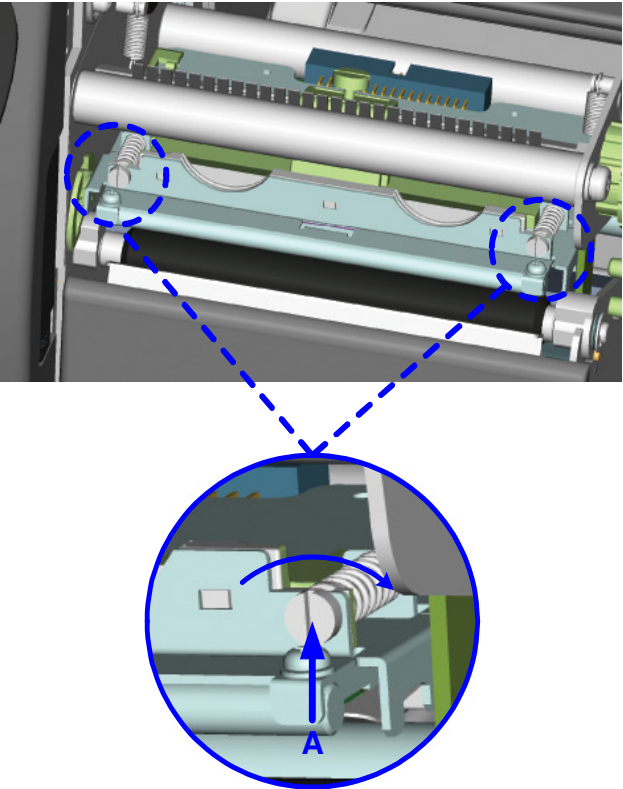
<p>1. Open the Top Cover.</p>	
<p>2. Pull the Printhead Lever out and rotate it upward to the right (counterclockwise) to open the Printhead.</p>	
<p>3. Move the Print Line all the way back by turning the screws on each side of the Printhead (marked A) counterclockwise.</p> <p>4. Then turn the screws clockwise a quarter turn at a time to move the Print Line forward. Adjust both screws by the same amount to ensure that the Print Line and the Platen Roller are parallel.</p> <p>5. Print a test label with a black bar across the entire width of the label to check print quality and repeat step 4 as necessary to achieve proper print quality.</p>	

Thermal Printhead Balance Adjustment

If one side of the printed labels is not being printed clearly, or if ribbon wrinkles occur, then adjust the Thermal Printhead Spring Box position to cure the problem.

1. Pull the Printhead Lever out and rotate it upward to the right (counterclockwise) to open the Printhead.
2. Move the Thermal Printhead Spring Box on the right side. Normally, the wider the paper, the farther the Thermal Printhead Spring Box will be from the center wall and for narrower paper, the Thermal Printhead Spring Box will be closer to the center wall.
3. To adjust the TPH Spring Box pressure, use a flat tip screwdriver to turn the screw clockwise to increase the pressure or counterclockwise to decrease the pressure.

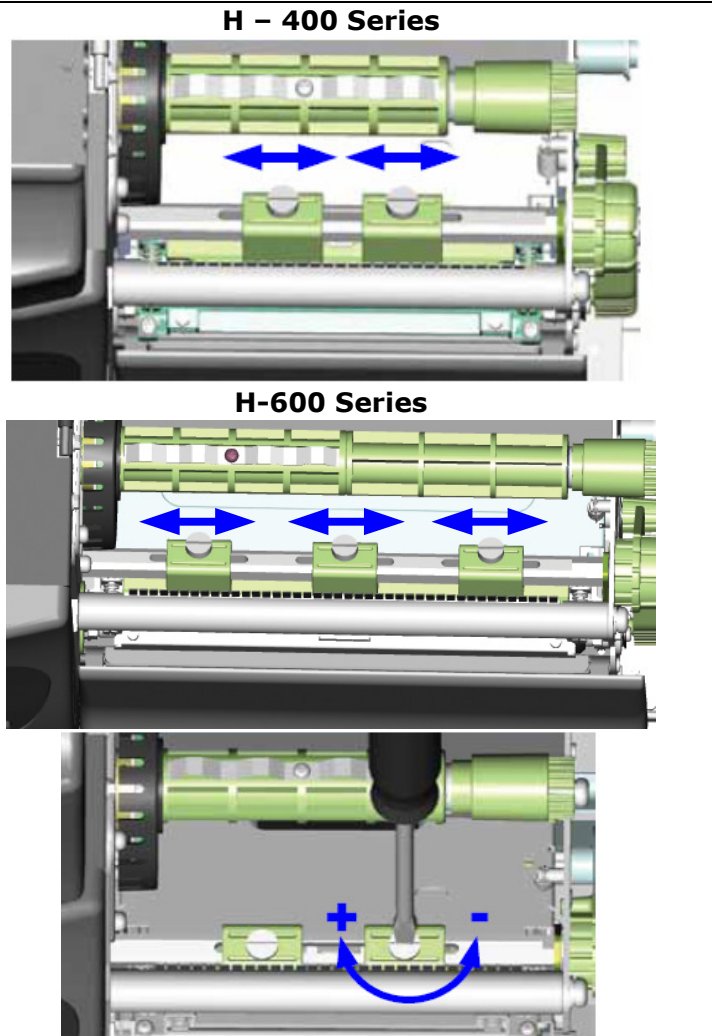

Ribbon Tension Adjustment

Due to differences in ribbon material, ribbon wrinkles may occur during printing. When this happens increase the ribbon tension by:

1. Pushing the end of the shaft in.
2. Then turn the ribbon shaft clockwise to increase the tension.

If narrower ribbons are being used (especially ribbon widths of less than 2"), the Printer might have a problem feeding labels. When this happens decrease the ribbon tension by:

1. Pushing the end of the shaft in.
2. Then turn the ribbon shaft counterclockwise to decrease the tension.

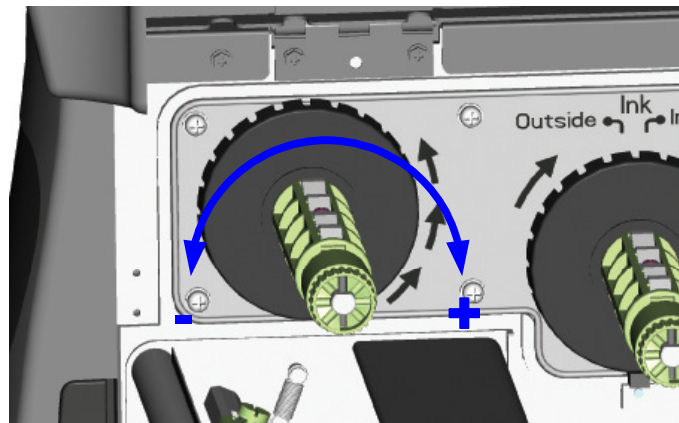

Ribbon Shield Adjustment

If ribbon wrinkle occurs during printing, adjust the ribbon shield.

Example: If ribbon wrinkle occurs as shown in figure (a), please turn the ribbon shield screw A clockwise, and if ribbon wrinkle occurs as shown in figure (b), please turn the ribbon shield screw B clockwise.



(a)



(b)

For best results, only adjust the screw by one half turn for each test print.

The maximum adjustment of the screw is two revolutions. If the screws are turned more than the acceptable range, the paper feed may not be smooth.

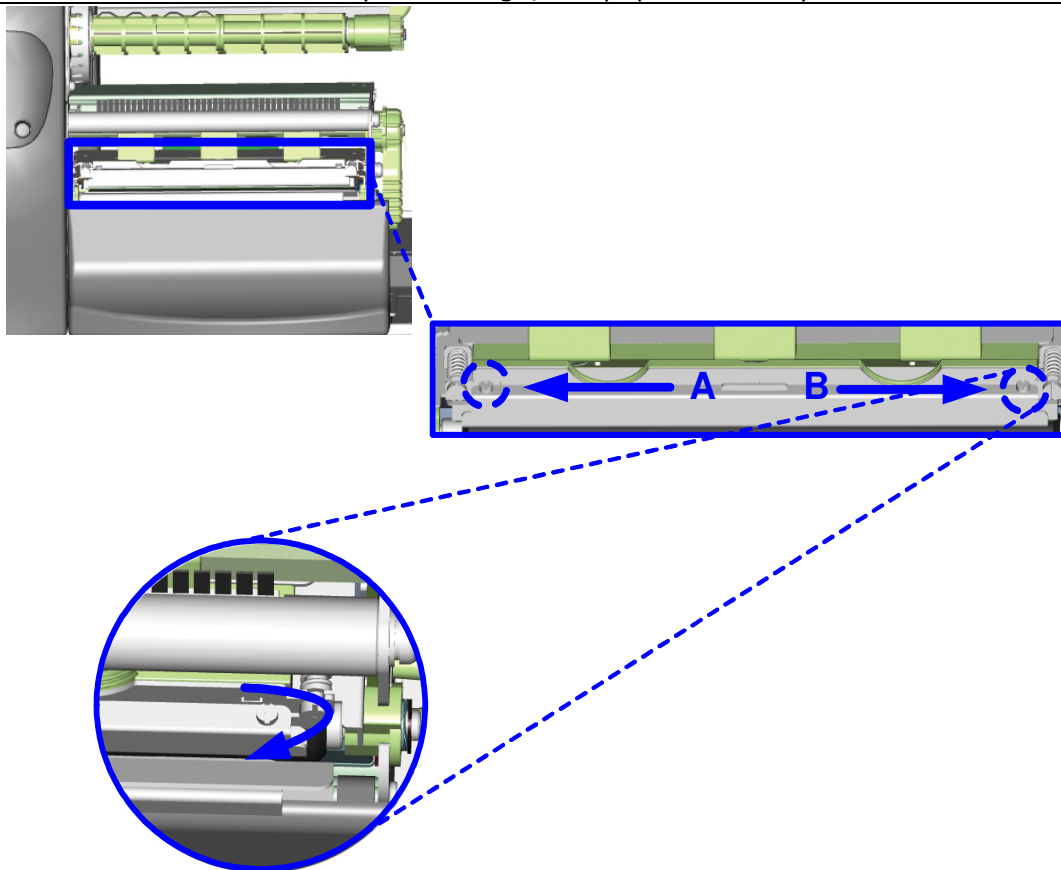

Auto Sensing

Using Auto Sensing the Printer automatically detects and records the label type and length (gap or black mark paper). Then the Printer can accurately detect the label positions.

1. Adjust the Moveable Sensor so that it is located in a position to sense the label gaps or black marks.
2. Turn the Printer Off and press and hold the PAUSE Key.
3. Turn the Printer On while holding down the PAUSE Key.
4. The Printer will beep 3 times and the LCD will display "Auto Sensing Mode" then release the PAUSE Key.
5. The Printer will now detect and record the label size/length.
6. The LCD will display the measurement in dots and the Printer will go back into Standby Mode.

NOTICE!



Generally, the Printer should be set to Auto Mode and the Auto Sensing procedure will detect the label stock correctly. Some label stock has gaps AND black marks. This can cause the Printer to NOT correctly detect the label stock. If this happens, the Auto Sensor Option should be set to Black Mode or Gap Mode based on what you wish to base the label size on.

Upgrading the Printer's Firmware

The Printer's firmware can be upgraded in the field by performing the following procedure:

1. Connect the Printer to a computer.
2. Unzip the firmware files and save them to a directory on your computer.
3. Start the Download Tool program by double clicking on DownloadTool.exe.
4. Select the port that is being used to communicate with the Printer and click the "Download Firmware" button. If downloading via the serial port the baud rate MUST be set to 115200 in the Printer.

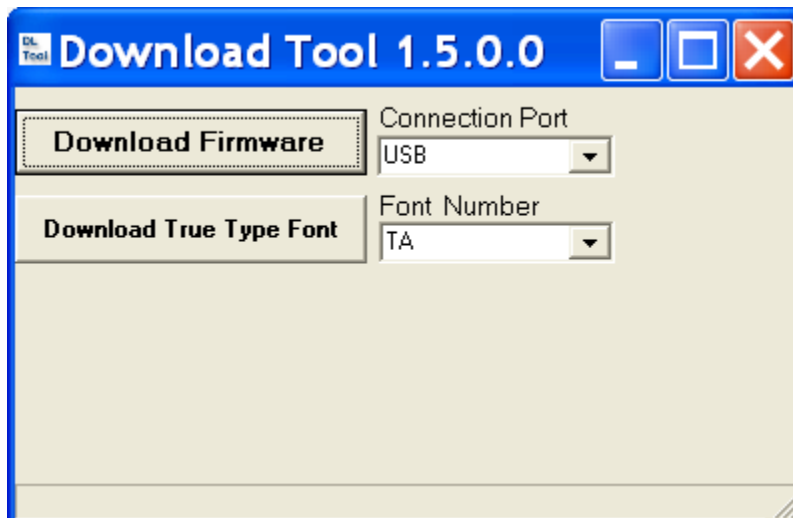

5. This will bring up a Browse Window displaying the firmware (.bin) files that can to be downloaded to the Printer. Select the appropriate firmware file (H400.BIN for the H-400 Series and H600.BIN for the H-600 Series) and click "Open".

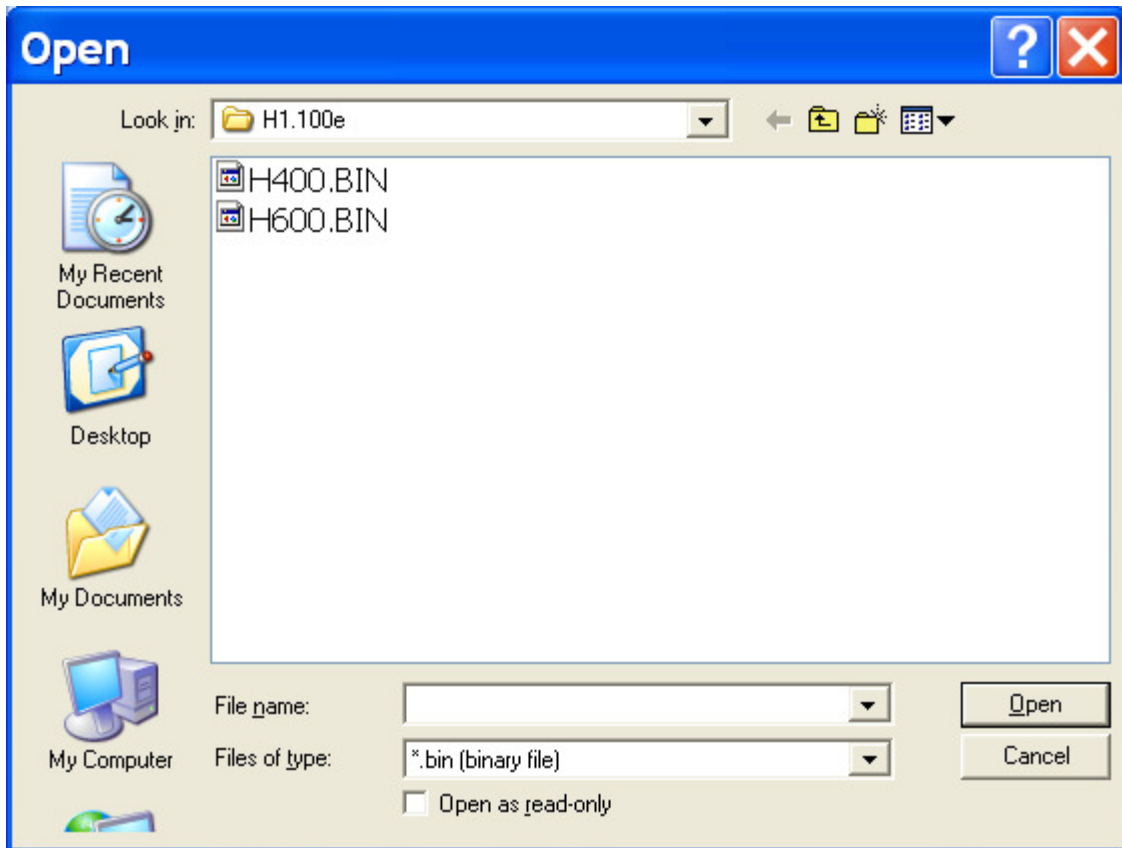

6. After the "Open" button is clicked, the firmware download process will start immediately. A blue progress bar will pop up to display the progress of download.
7. When the progress bar reaches "100%", the firmware download is complete. As the download finishes, the Ribbon and Media light will alternately flash slowly and then rapidly.
8. The Printer will now reset. Please wait for the Printer to complete the reset procedure. The Printer will return to "Ready to print" status after the reset.
9. The new firmware version will be displayed on the Printer's LCD. This confirms that the firmware has been updated.

Downloading True Type Fonts to the Printer's Flash Memory

1. Start the Download Tool program by double clicking on DownloadTool.exe.
2. Select a 'Font Number' that will be used to identify the downloaded True Type Font.

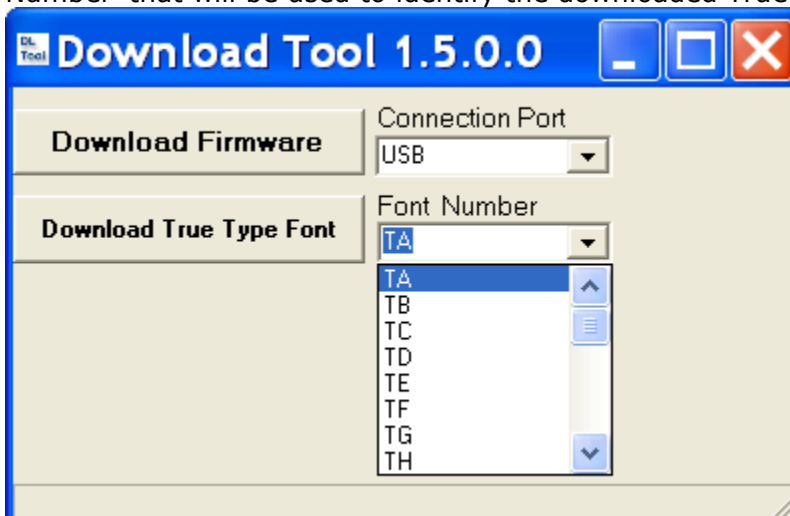

3. Click the "Download True Type Font" button, the program will show a list of TrueType Fonts that are available for download. Select a TrueType Font and click "OK".

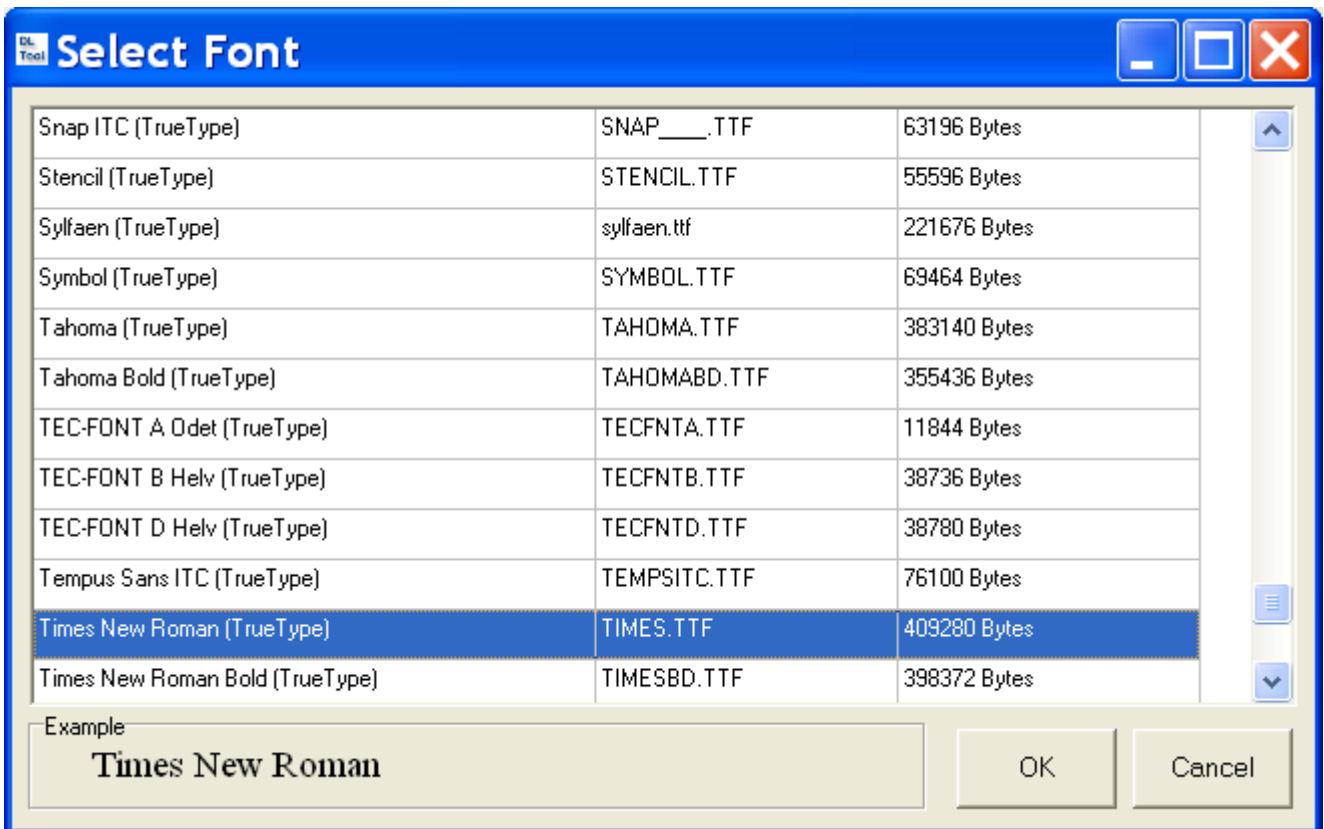

4. After the "Open" button is clicked, the download process will start immediately. A blue progress bar will pop up to display the progress of the download.
5. When the progress bar reaches "100%", the TrueType Font download is complete and the TrueType Font is stored in the Printer's Flash memory.

Clearing Cutter Jams on the H-400 Series Cutter

1. If the Cutter jams or malfunctions turn the Printer Off.
2. There is a hole (marked "A") on each side of the Cutter. Insert a 3mm hex key into one of these holes and use the key to turn the cutter blade clockwise.
3. After the problem is corrected, turn the Printer back on and the cutter blade will go back to its original position.

Note: It is recommended to use labels greater than 35mm (1.38") in height in order for them to clear the Cutter.

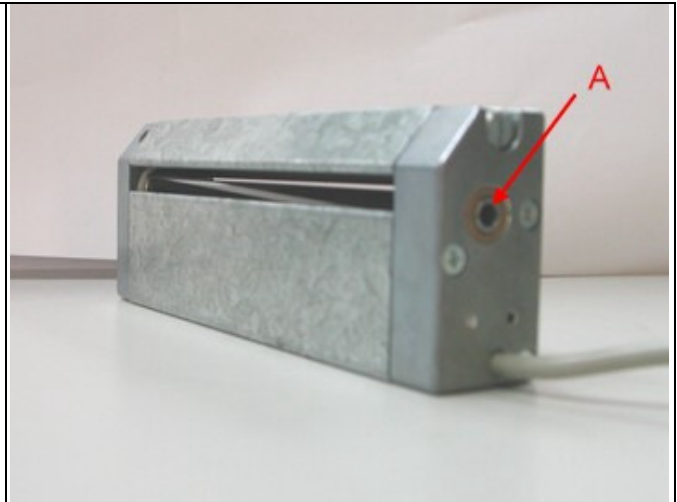

Cleaning Adhesive from the H-400 Series Cutter Blade

When using adhesive labels, the cutter may malfunction due to a build up of adhesive on the blade. When this happens it will be necessary to clean the Cutter Blade:

1. Turn the Printer Off.
2. Remove the Cutter assembly from the Printer.
3. Wet a cotton swab in Isopropyl Alcohol and use it to remove any build-ups of adhesive.
4. There is a hole (marked "A") on each side of the Cutter. Insert a 3mm hex key into one of these holes and use the key to turn the cutter blade clockwise to allow access to the entire length of the blade.
5. Allow the Cutter to dry for 10 minutes.
6. Re-install the Cutter assembly and turn the Printer back On. The cutter blade will go back to its original position.

